

# PTL Low Pressure Hose Pumps

Original Instruction  
2021 | 4



Read this instruction manual carefully,  
before you install and operate the pump



Pump models:

<b>PTL</b>
9
13
17
25
30
45

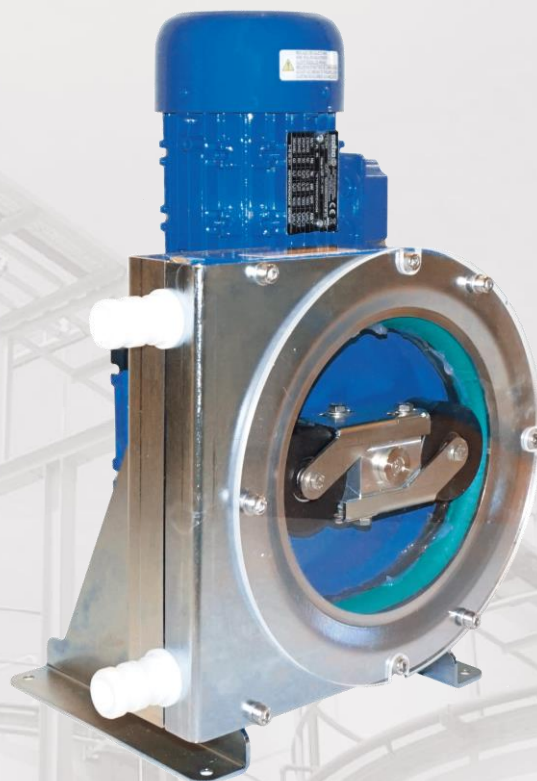

# CONTENTS

---

<b>EC DECLARATION OF CONFORMITY 02/EU/PTL/2021 .....</b>	<b>4</b>
<b>0. GENERAL .....</b>	<b>5</b>
0.1. Introduction.....	5
0.2. Warning symbols .....	5
0.3. Qualification and training of personnel.....	5
0.4. Nameplate .....	6
<b>1. INSTALLATION .....</b>	<b>7</b>
1.1. Operation principle.....	7
1.2. Receiving inspection.....	7
1.3. Lifting and transportation.....	7
1.4. Storage.....	8
1.5. Foundation .....	8
1.6. Environment .....	8
1.7. Suction and discharge piping .....	8
1.7.1. Connection of suction pipe .....	9
1.7.2. Connection of discharge pipe .....	9
1.8. Health and safety .....	9
1.8.1. Protection .....	10
1.8.2. Electrical safety .....	10
1.8.3. Chemical hazard .....	10
1.8.4. Noise level .....	10
1.8.5. Temperature hazards.....	10
1.8.6. Rotating parts.....	11
1.8.7. Cleaning and disinfection.....	11
1.9. Installation recommendations .....	11
1.9.1. Minimum required distance for hose removal .....	11
1.10. Instruments.....	12
1.10.1. Electric power .....	12
1.10.2. Optional instruments.....	12
1.10.3. Thermometer.....	12
1.10.4. Pressure safety device .....	12
1.11. Motor connection .....	13
1.12. Gear-motor standard .....	13
<b>2. OPERATION .....</b>	<b>14</b>

# CONTENTS

---

2.1.	Before starting the pump .....	14
2.2.	Starting and operation .....	14
2.2.1.	Dry running .....	15
2.2.2.	Dead head .....	15
2.2.3.	Optimization of the pump lifetime .....	15
2.3.	Pump stopping .....	15
2.4.	Cleaning and disinfection .....	16
2.5.	Residual risks .....	16
2.6.	Disposal after expiration of the expected lifetime .....	16
2.7.	Waste of electrical and electronic equipment (WEEE) directive .....	16
2.8.	Actions in emergency .....	16
3.	MAINTENANCE .....	17
3.1.	Inspections .....	17
3.2.	When the pump is new or reassembled .....	17
3.2.1.	Performance test .....	17
3.3.	Routine inspection .....	17
3.4.	Complete inspection .....	18
3.5.	Location of faults .....	18
3.6.	Disassembly of the pump .....	19
3.6.1.	Before the disassembly procedure .....	19
3.6.2.	Disassembly procedure .....	20
3.6.3.	Test run .....	22
3.7.	Hose cleaning .....	23
3.8.	Hose replacement .....	23
3.9.	Roller adjustment .....	27
4.	SPARE PARTS .....	30
4.1.	Exploded view PTL9 – PTL17 .....	30
4.2.	Spare parts list PTL9 – PTL17 .....	30
4.3.	Exploded view PTL25 – PTL45 .....	32
4.4.	Spare parts list PTL25 – PTL45 .....	32
4.5.	Stocking recommendation .....	33
4.6.	How to order parts .....	34
4.7.	Pump code .....	35
5.	DATA .....	36
5.1.	Capacity curves .....	36
5.2.	Technical data .....	37

# CONTENTS

---

5.3. Dimensions .....	38
5.3.1. PTL9 – PTL17 .....	38
5.3.2. PTL25 – PTL45 .....	39
5.4. Tightening torques .....	40
5.5. Permitted loads on manifolds.....	41
6. WARRANTY .....	42
6.1. Warranty form.....	42
6.2. Returning parts .....	43
6.3. Warranty .....	43

## EC DECLARATION OF CONFORMITY 02/EU/PTL/2021

Series: PTL(...)9...; PTL(...)13...; PTL(...)17...; PTL(...)25...; PTL(...)30...; PTL(...)45...

Manufactured by:

**Tapflo AB**  
**Filaregatan 4**  
**442 34 Kungälv, Sweden**

This declaration of conformity is issued under the sole responsibility of the manufacturer.

Object of declaration: **LOW PRESSURE HOSE PUMPS**

The object of the declaration described above is in conformity with the relevant Union harmonisation legislation:

- Directive 2006/42/EC of European Parliament and of the Council of 17 May 2006 on machinery, amending Directive 95/16/EC;
- Directive 2014/30/EU of the European Parliament and of the Council of 26 February 2014 on the harmonisation of the laws of the Member States relating to electromagnetic compatibility (recast) Text with EEA relevance
- Directive 2014/35/EU of the European Parliament and of the Council of 26 February 2014 on the harmonisation of the laws of the Member States relating to the making available on the market of electrical equipment designed for use within certain voltage limits Text with EEA relevance

Mr Michał Śmigiel is authorized to compile the technical file.

Tapflo Sp. z o.o.  
ul. Czatkowska 4b  
83-110 Tczew



Signed for and on behalf of Tapflo AB

A handwritten signature in purple ink, appearing to read 'Håkan Ekstrand'.

Håkan Ekstrand  
**Managing director**

Kungälv, 13.12.2021 r.

# 0. GENERAL

---

## 0. GENERAL

### 0.1. Introduction

The Tapflo Hose Pump range is a series of pumps for industrial and hygienic applications. The pumps are designed to be safe, simple and easy to use and maintain. The pumps are suitable for almost all different liquids used by the industry today.

The pumps are powered with an electric motor which is coupled with the rotor. To decrease the motor rotational speed a gearbox is used.

With proper attention to maintenance, Tapflo Pumps will give efficient and trouble free operation. This instruction manual will familiarise operators with detailed information about installing, operating and maintaining of the pump.

When installing, operating and maintaining of the pump unit you must strictly follow the IOM manual. Otherwise injury or life hazard may occur.

In case any instructions in this manual are unclear or any information is missing, please contact Tapflo before handling the pump.

### 0.2. Warning symbols

The following warning symbols are present in this instruction manual. This is what they say:



This symbol stands next to all safety instructions in this instruction manual where danger to life and limb may occur. Observe these instructions and proceed with utmost caution in these situations. Inform also other users of all safety instructions. In addition to the instructions in this instruction manual, the general safety and accident prevention regulations must be observed.



This signal stands at points in this instruction manual of particular importance for compliance with regulations and directives, for correct work flow and for the prevention of damage to and destruction of the complete pump or its subassemblies.



This symbol signals possible danger caused by the presence of electric fields or live wires.

### 0.3. Qualification and training of personnel



The personnel in charge of installation, operation and maintenance of the pumps we produce must be qualified to carry out the operations described in this manual. Tapflo shall not be held responsible for the training level of personnel and for the fact that they are not fully aware of the contents of this manual. In case any instructions in this manual are unclear or any information is lacking, please contact Tapflo before handling the pump.

# 0. GENERAL

---

## 0.4. Nameplate

The nameplate is made in the below design. It is made of AISI 304 stainless steel and placed on the pump stand or discharge flange bracket. Nameplate dimensions are 38 x 48 mm.



# 1. INSTALLATION

## 1. INSTALLATION

### 1.1. Operation principle

The Tapflo hose pump is driven by a gear-motor. The rotor is installed directly on the shaft and is equipped with rollers. The rollers compress the hose creating vacuum on the suction side of the pump and pressure on the discharge to transfer the liquid. The rotary movement of the rollers compresses the hose along the casing wall, constantly sucking/pushing the liquid through the hose. The hose is the only part of the pump that is in contact with the liquid.

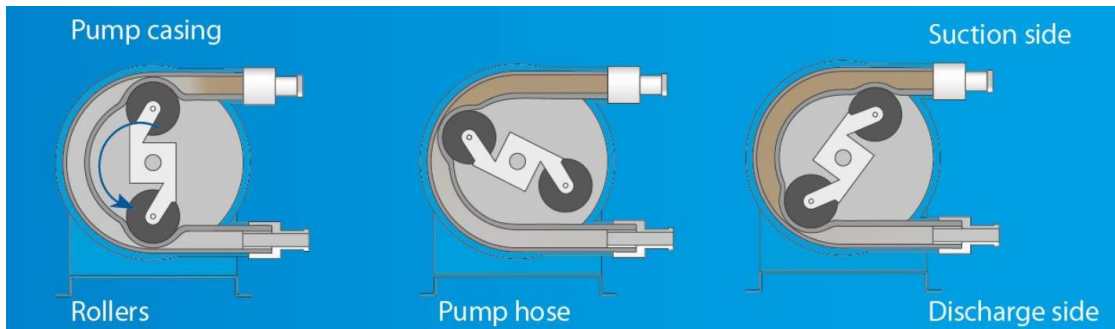

### 1.2. Receiving inspection

Although precaution is taken by us when packing and shipping, we urge you to carefully check the shipment on receipt. Make sure that all parts and accessories listed on the packing list are accounted for. Immediately report any damage or shortage to the transport company and to us.

### 1.3. Lifting and transportation



Before handling the pump check the weight of the pump (see 5. *Data*). Refer to Your local standards on how to handle the pump. If the weight is excessive to transport by hand it must be lifted using slings and a suitable lifting device e.g. a crane or forklift.

The pump is equipped with eye bolts to ease transportation.

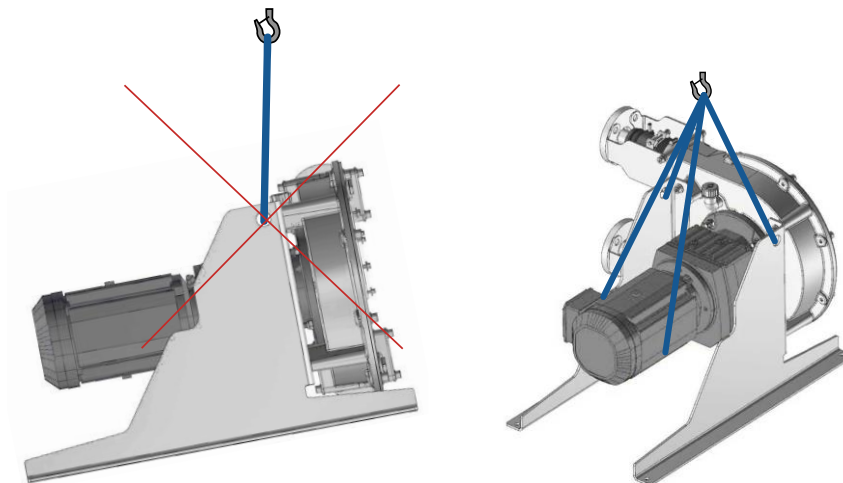



# 1. INSTALLATION

---

Never lift the pump under pressure.

Be careful that nobody passes under the pump when lifted.

Never try to lift the pump by the manifolds or hoses attached to the pump.

## 1.4. Storage



If the equipment is to be stored prior to installation, place it in a clean location. The pump should be stored in an ambient temperature of 15°C (59°F) to 25°C (77°F) and relative humidity below 65%. It should not be exposed to any heat source e.g. radiator, sun as this could result in a negative way on the tightness of the pump. Do not remove the protective covers from the pump.

When in storage, turn the shaft by hand at least twice per month. The pump-motor unit should always be stored indoor in dry, vibration and dust free conditions. If the pump is to be stored more than 1 month, remove the hose form the pump. If this is not possible, run the pump 10 min per week.

Spare hoses must be stored in the same conditions as the pump. What is more, they should be protected from direct sunlight. Rubber materials are subject to aging and their performance and lifetime decrease with time.

**NOTE!** Do not remove protective covers from the hose when in storage.

## 1.5. Foundation



The pump-motor unit must stand on and be fixed to a sufficiently rigid structure that can support the entire perimeter on which the unit stands. The foundation on a firm bottom is the most satisfactory. Once the pump is in position, adjust level with metal shims between the feet and the surface on which it stands. Check that the feet of the pump motor unit stand well on each of them. The surface on which the foundation stands must be flat and horizontal. If the unit is fitted on a steel structure, make sure that it is supported so that the feet do not warp. In any case, it is advisable to fit some anti-vibration rubber pieces between the pump and the brickwork.

## 1.6. Environment



- There should be enough space in the vicinity of the pump in order to operate, maintain and repair it.
- The area in which the pump is operated, must be sufficiently ventilated. Excessive temperature, humidity or dirt may affect the pump operation.
- Behind the cooling fan of the motor there must be sufficient room for the hot air to escape the motor.

## 1.7. Suction and discharge piping

A pump is generally part of a piping system that can include a number of components such as valves, fittings, filters, expansion joints, instruments, etc. The way the piping is arranged and the positioning of the components has a great influence on the operation and the lifetime of the pump. The pump cannot be used as a support for the components connected to it.

The flow of liquid from the pump must be as even as possible. It is advisable to avoid any tight bends or drastic reductions of diameters that may cause flow resistance in the installation. In

# 1. INSTALLATION

---

case of diameter reduction, it is advisable to use appropriate conical reductions (possibly eccentric on suction side and concentric on discharge side) at changes of diameter and at a minimum distance from pump connections of five diameters.

## 1.7.1. Connection of suction pipe

Remember that the suction pipe/connection is the most critical point, especially if the pump is priming. Just a small leakage will dramatically reduce the suction capability of the pump. When connecting the suction pipe, the following is recommended:

- 1) For satisfactory operation, use a reinforced hose (the suction power may otherwise shrink the hose) or other flexible piping. The internal diameter of the hose should be at least same as on the suction connection (at the bottom of the pump) to have best suction capability. If the diameter of a hose is smaller, it will affect the pump's performance or cause its malfunction.
- 2) Make sure that the connection between the hose and the pump is completely tight, otherwise the suction capability will be reduced.
- 3) Always use as short suction pipe as possible. Avoid air pockets which can emerge within long piping.

## 1.7.2. Connection of discharge pipe



For this connection it is only recommended to have a simple and positive flow connection. Use a hose or flexible piping (minimum one meter) between the discharge connection and any rigid fixed piping. Coil the hose at least one turn. All components (hose, pipe, valves etc.) on the discharge piping must be designed for appropriate PN, according to pump maximum pressure. It is recommended to install a check-valve on the discharge side in order to protect the pump from water hammer effect that can be created in the discharge pipeline. If overpressure in the discharge line is possible, an appropriate pressure safety device should be installed to protect the pump. A device must be incorporated into the pump, system, or drive, to prevent the pump exceeding the rated pressure. Do not allow the pump to operate with a closed/blocked discharge unless a pressure relief device is installed.

A pressure relief valve must be assembled obligatory on the discharge side by the customer if overpressure in the system is possible.

## 1.8. Health and safety

The pump must be installed according to local and national safety rules.



**The pumps are constructed for particular applications. Do not use the pump on applications different from that for which it was sold without consulting us to ascertain its suitability.**

**The pumps are tested with water. If the pumped product can come into reaction with water, please make sure the pump is dry before putting it into operation.**

# 1. INSTALLATION

---

## 1.8.1. Protection



In the interest of health and safety it is essential to wear protective clothing and safety goggles when operating, and/or working in the vicinity of Tapflo pumps.

## 1.8.2. Electrical safety



Do not carry out any maintenance or/and operation on the pump while it is running or before it has been disconnected from the power supply. Avoid any danger caused by electric power (for details see current regulations in force). Check that electrical specifications on the data plate are equivalent to the power supply to which it will be connected.

## 1.8.3. Chemical hazard



Whenever the pump is to be used for pumping a different liquid, it is essential to clean the pump beforehand in order to avoid any possible reaction between the two products.

## 1.8.4. Noise level



Hose pumps, including the motor, in normal operating conditions produce a sound level below 70 dB(A). The major sources of noise are: liquid turbulence in the installation, cavitation or any other abnormal operation that is independent from the pump construction nor the pump manufacturer. The user must provide suitable protective means if the sources of noise could produce a harmful noise level for operators and for the environment (in compliance with current local regulations).

## 1.8.5. Temperature hazards

- Raised temperature can cause damage on the pump and/or piping and may also be hazardous for personnel in the vicinity of the pump/piping. Avoid quick temperature changes and do not exceed the maximum temperature specified when the pump was ordered. See also general max temperatures based on water in chapter 5. *Data*



- When the pump is exposed to ambient temperature variations or if there is big difference between the temperature of the product and the surrounding, the tightening torques of the housing nuts should be checked periodically as part of preventive maintenance (please contact Tapflo for interval proposals). Ambient temperature limits are from -20°C to +40°C.



- If a hot product is pumped, the pump should not stand still when filled for a longer period of time. This could cause leakage from the pump.
- Below 0°C (32°F) plastic materials become more fragile what can cause accelerated wear of parts made of these materials. This is a hazard that has to be accepted when pumping such cold products. Also in such case, when a pump is not operational it should be drained of all liquid.
- Bear in mind that the viscosity of the product changes with temperature. This has to be taken into consideration when selecting the pump.

# 1. INSTALLATION

- The fluid remaining in the connected piping, as well as in the pump itself, may expand because of freezing or heat, which may cause damage to the pump or/and piping, and lead to leakage of the fluid.
- Some parts of the hose pump can become hot during operation and cause burns, therefore make sure to use appropriate protection when handling the pump.

## 1.8.6. Rotating parts



Do not tamper with the protection of the rotating parts, do not touch or approach rotating parts in movement.

## 1.8.7. Cleaning and disinfection



Cleaning and disinfection of the pump system is of greatest importance when the pump is used in a food process installation. Use of a pump system that is NOT cleaned or disinfected can cause contamination of the product

## 1.9. Installation recommendations

- If liquid contains solid particles bigger than max allowable size for the corresponding pump size, a strainer on the suction side should be used.
- Manometers or pressure sensors must always be installed on the suction and discharge side of the pump to determine proper operation of the pump.
- The suction and discharge piping must be fastened properly so that no strain occurs on the pump manifolds.
- It is recommended to install a check-valve on the discharge side in order to protect the pump from water hammer effect that can be created in the discharge pipeline.
- The suction line should be as short and straight as possible.
- A gate valve could be installed on the discharge line for easier pump disconnection from the pipeline (**ATTENTION!** The gate valve should never be closed during pump operation).
- A pressure relief valve must be assembled obligatory on the discharge side by the customer if overpressure in the system is possible. A device must be incorporated into the pump, system, or drive, to prevent the pump exceeding the rated pressure.

### 1.9.1. Minimum required distance for hose removal

During pump installation provide enough space to be able to perform hose replacement procedure. Please follow the guideline below:

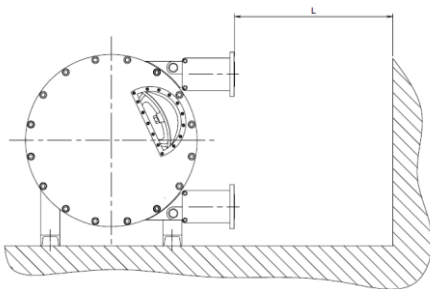

PUMP	L [mm]
PTL9	400
PTL13	400
PTL17	600
PTL25	700
PTL30	1200
PTL45	1500

# 1. INSTALLATION

---



## **NOTE!**

Even if all above safety instructions are met and complied with, there still exists a minor danger in the event of a leakage or mechanical damage of the pump. In such case the pumped product can emerge on sealing areas and connections.

## **1.10. Instruments**



In order to ensure a proper control of the performance and the conditions of the installed pump, we recommend using the following instruments:

- a pressure-vacuum gauge on the suction piping;
- a pressure gauge on the discharge piping.

The pressure intakes must be made of straight pieces of piping at a distance of minimum five diameters from the pump inlets. The pressure gauge on discharge must always be fitted between the pump and the regulation valve. The output can be read on the pressure gauge, transformed into meters and then compared with the typical curves.

### **1.10.1. Electric power**

The electric power absorbed by the motor can be measured by means of a wattmeter or an amp gauge.

### **1.10.2. Optional instruments**

The optional instruments can indicate if pump is working in an abnormal way. The abnormal conditions can be caused by: accidentally closed valves, lack of pumped liquid, overloads, etc.

### **1.10.3. Thermometer**

If the temperature of the pumped liquid is a critical parameter, provide the installation with a thermometer (preferably on the suction side).

### **1.10.4. Pressure safety device**

The pump cannot run against higher pressure than stated in this IOM manual. Therefore the pump must be equipped with an appropriate pressure safety device such as a pressure switch, bypass line with a pressure relief valve or motor overload protection that will automatically stop the pump when pressure rises above allowable levels.

# 1. INSTALLATION

## 1.11. Motor connection



An expert electrician must always carry out the electrical connection. Compare the power supply with the data plate specifications and then choose a suitable connection. The type of connection is stated on the motor data plate and can be Y (star) or D (Delta), according to the power supply of the motor (see figure below).

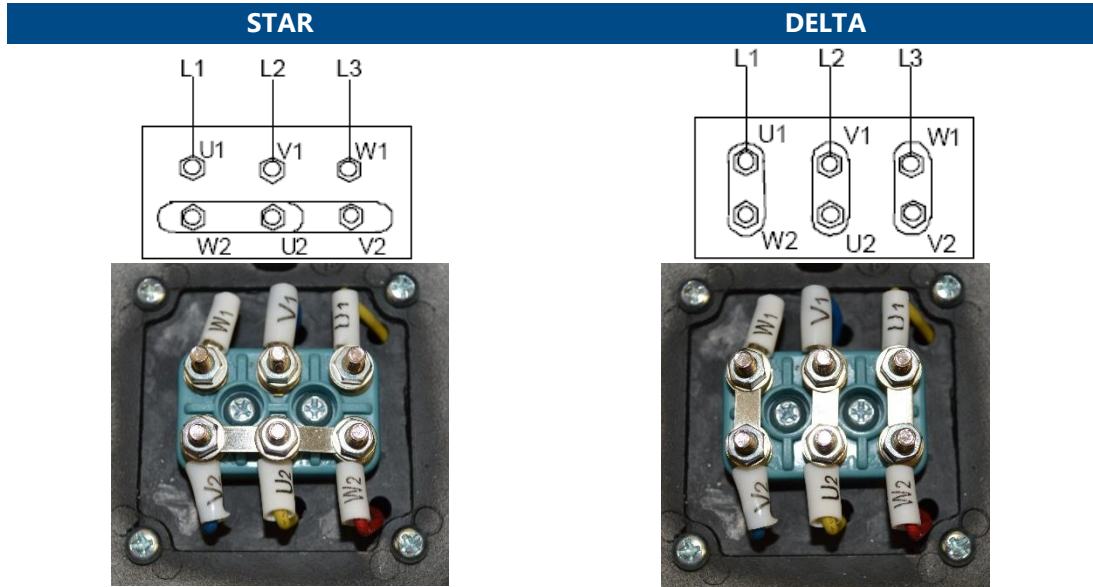

Follow the connection standard used in the plant. In no case connect the electrical motor directly to supply network but use a suitable electric switchboard equipped with a knife switch and suitable safety devices (e.g. motor breaker switches) in the power circuit. Safety devices against overloads must also protect the motors. Make sure that the motor has suitable grounding and that it has been connected properly.

## 1.12. Gear-motor standard

As a standard Tapflo Hose pump are equipped with gear-motors of the following parameters:

- International Mounting Arrangement – **B5**
- Number of poles / Rotation speed [rpm] – **4 / 1400**
- **Non ATEX**
- Protection grade – **IP55**
- Voltage – **3 phase; 230/400 V; 50 Hz**
- Efficiency class – **IE3**
- Output rpm – **23 ÷ 143 @ 50 Hz**
- Thermal protection – **PTC**

The rated gear-motor rpm should not be exceeded. If you want to operate the pump at higher speed please consult Tapflo for guidelines.

## 2. OPERATION

---

### 2. OPERATION

#### 2.1. Before starting the pump



- Make sure the pump is installed according to the installation instructions (chapter 1).
- Filling of the pump with liquid before start is not necessary.
- Check manually that the motor is free to turn, moving the motor cooling fan.
- Make sure that the piping is not clogged and is free from residues or foreign objects.
- The suction shut-off valve (if any) must be completely open.
- The shut-off valve on the discharge side (if any) must be completely opened.
- Any auxiliary connections must all be connected.
- Make sure that the rollers are adjusted correctly, according to the desired process.
- When installation is new or reinstalled, a test run of the pump with water should be conducted to make sure that the pump operates normally and does not leak.
- When installation is new or reinstalled, check the pump housing nuts tightening torque (see chapter 5.4. *Tightening torques*). After approximately one week of operation, the torque should be checked again. This is important to prevent possible leakage.
- Starting the electrical motor makes the pump run at full capacity!

#### 2.2. Starting and operation



Open the discharge valve and start the electric motor. The pump must not run with completely closed discharge - these conditions can seriously damage the pump and cause injury to the operator.



If the pressure shown on the pressure gauge on the discharge piping does not increase, turn off the pump immediately and release pressure carefully. Repeat the connection procedure.



**Make sure that pressure on the discharge does not exceed the rated pressure!**

**A device must be incorporated into the pump, system, or drive, to prevent the pump exceeding the above rated pressure. Do not allow the pump to operate with a closed/blocked discharge unless a pressure relief device is installed.**

**A pressure relief valve must be assembled obligatory on the discharge side by the customer.**

Pump can be equipped with such a safety device on customer's request.

If there are changes of flow rate, head, density, temperature or viscosity of the liquid, stop the pump and get in touch with our technical service.

The performance of the pump can be adjusted by means of a frequency inverter. The pump operation does not depend upon the direction of rotation and can achieve full capacity in both directions of rotation.

## 2. OPERATION

---

### 2.2.1. Dry running

Although the pump is prepared for dry running it is important to have in mind that long periods of dry run may cause damage to the wearing parts of the pump. What is more, an empty pump should operate at low speeds – controlled by a frequency inverter.

### 2.2.2. Dead head



The pump cannot operate with closed discharge valve. This may lead to pump malfunction and cause injury to operators in the vicinity of the pump.

The discharge pressure can never exceed pump rated pressure.

### 2.2.3. Optimization of the pump lifetime

- Continuous operation at higher frequency than 50 Hz will cause premature wear of the components. As a general rule, we recommend to run the pump at  $\pm 20\%$  of the rated frequency.
- When reducing the motor rotation speed, control the gear-motor surface temperature if it does not exceed the nominal working temperatures stated by the gear-motor manufacturer.

## 2.3. Pump stopping



Turn off the motor to stop the pump. Close the discharge shut-off / regulation valve immediately after. The reverse sequence is not recommendable, especially with larger pumps or longer delivery piping. That is to avoid any problems due to water hammering. It is therefore advised to install a check valve on the discharge to protect the pump. If a suction shutoff valve has been installed, it is advisable to close it completely after pump is fully stopped.



The pump should be stopped by cutting of electrical power to the motor or frequency inverter (if used – at 50 Hz cool down should be set to 5 seconds).

**NOTE!** Never stop the pump by completely closing the discharge valve without motor shut down.



## 2. OPERATION

---

### 2.4. Cleaning and disinfection



Cleaning and disinfection of the pump system is of greatest importance when the pump is used in a food processing installation. Use of a pump system that is NOT cleaned or disinfected can cause contamination of the product. The cleaning cycles as well as chemicals to use for the cleaning vary depending on the pumped product and the process. The user is responsible to establish a suitable cleaning and / or disinfection program according to local and public health and safety regulations.



If the outside of the pump is to be rinsed or flushed, the power supply must be disconnected beforehand.

### 2.5. Residual risks



Even with proper application and observance of all points listed in this operating manual, there is still an estimable and unexpected residual risk when using the pumps. It may leak, fail due to wear, application-related causes or system-related circumstances.

### 2.6. Disposal after expiration of the expected lifetime

Pump components can be recycled, it must be disposed of properly, according to local regulations. It should be noted that potentially dangerous fluid residues may remain in the pump and can create a hazard to the operator or the environment, therefore the pump has to thoroughly cleaned before disposal.

### 2.7. Waste of electrical and electronic equipment (WEEE) directive



Users of electrical and electronic equipment (EEE) with the WEEE marking per Annex IV of the WEEE Directive must not dispose of end of life EEE as unsorted municipal waste, but use the collection framework available to them for the return, recycle, recovery of WEEE and minimize any potential effects of EEE on the environment and human health due to the presence of hazardous substances. The WEEE marking applies only to countries within the European Union (EU) and Norway. Appliances are labelled in accordance with European Directive 2002/96/EC. Contact your local waste recovery agency for a designated collection facility in your area.

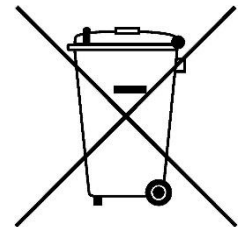

### 2.8. Actions in emergency



In case of a leakage of an unknown fluid, respiratory protection should be worn and contact with the fluid avoided. During firefighting, no special hazards are to be expected from the pump itself. In addition, the currently handled fluid and the corresponding safety data sheet must be taken into account. When fluid leakage occurs, the power supply has to be closed and the pressure released. During spillage of an aggressive liquid, local and national safety rules must be followed.

## 3. MAINTENANCE

---

### 3. MAINTENANCE



**Maintenance work on electrical installations must be performed by qualified personnel and only when the power supply has been shut off. Wait five minutes for capacitor to discharge before opening the pump. Follow the local and national safety regulations.**

Due to size of some of the pumps at least two persons should perform maintenance activities and if needed use appropriate lifting devices according to local rules and regulations.

#### 3.1. Inspections

- Periodically check suction and discharge pressures.
- Inspect the gear-motor according to the instructions from the motor manufacturer.
- Gearbox oil must be exchanged in accordance with the gearbox manufacturer instruction manual.

#### 3.2. When the pump is new or reassembled



**If the pump is new or reassembled after maintenance it is important to retighten the screwed connections after one week of operation.**

Make sure to use the right torque – see chapter 5.4. *Tightening torques.*

##### 3.2.1. Performance test

When installation is new, a test run of the pump should be conducted. Gauge the capacity at specific pump speed. This information is useful for checking performance in the future as wear takes place. You will be able to set schedules for maintenance of the pump and to select spare parts to be kept on stock.

#### 3.3. Routine inspection



Frequent observation of the pump operation is recommended to detect problems. A change in sound of the running pump can be an indication of wearing parts (see chapter 3.5 "Location of faults" below). Hose damage can be the main reason of liquid leakage therefore it is advisable to install a hose rupture monitoring system that can detect the hose damage and stop the pump when liquid enters the pump chamber.

Leaking liquid from the pump and changes of performance may also be detected. Routine inspections should be conducted frequently. We recommend to conduct a daily check and keep records of the following:

- Leakage of fluid from any connection of the pump
- Tightness of all connection parts of the pump and any peripheral equipment
- Complete inspection in regular intervals has been done

In case any of the above is not fulfilled, do not start the pump and implement corrective actions.

Establish a preventive maintenance schedule based on the pump's service history. Scheduled maintenance is especially important to prevent spills or leakage due to hose failure.

## 3. MAINTENANCE

### 3.4. Complete inspection



The intervals for a complete inspection depend upon the operation conditions of the pump. The characteristics of the liquid, temperature, materials used in the pump and running time decide how often a complete inspection is necessary.

Nevertheless, Tapflo recommends to inspect the pump at least once a year.

If a problem has occurred, or if the pump is in need of a complete inspection, refer to chapters 3.5 "Location of faults" and 3.6 "Disassembly of the pump". You are of course warmly welcome to consult Tapflo for further help.

Parts that are subject to wear should be kept in stock, see our recommendations in chapter 4.7 "Stocking recommendation".

### 3.5. Location of faults

PROBLEM	POSSIBLE ISSUE	POSSIBLE SOLUTION
<b>Pump does not run</b>	Lack of power supply  The rotor is stalling	Check if the motor is connected properly Check if power supply is ON Check the fixing of the hose Check if the discharge pressure is not too high Check if particles are not blocking the hose
<b>The suction is bad</b>	Suction connection is not tight Suction connection is blocked Hose is blocked or damaged Air in suction / discharge line	Tighten the suction line Clean suction line Check for any debris inside the hose Vent suction / discharge line
<b>The pump runs irregular</b>	Hose is blocked or damaged	Check for any debris inside the hose
<b>Bad flow/pressure</b>	Wrong set-up of the rollers Suction blocked Pressure losses on suction side Too viscous liquid Air in liquid  Hose is blocked or damaged	Check and adjust if necessary Check / clean suction connection Check/change installation on suction side Check if pump speed is proper for viscosity Seal suction line; check / refill container Check for any debris inside the hose, replace hose if necessary
<b>Liquid leaks from the pump</b>	Screws on the pump not properly tightened Shaft seal or seal ring worn Tension / stress from the installation	Check tightening torques of the screws  Replace if necessary Adjust installation, eliminate stress, when using a dampener provide separate support for it.
<b>Hose life is too short</b>	Wrong selection of material Long periods of dry running Too high discharge pressure  Too high speed Wrong set-up of the rollers Too high liquid temperature	Contact us for information on material selection When dry, run pump slowly (see chapter 2.2) Check if pump rated pressure is not exceeded Check if the discharge line is not blocked Reduce the pump speed Check and adjust if necessary Contact us for information on material selection
<b>Overheating of motor</b>	Flow rate too high Liquid parameters different than calculated	Reduce the flow / rotation speed of the motor Check pumped liquid parameters
<b>Overheating of the pump</b>	Flow rate too high Liquid temperature too high Foreign objects in the liquid Pump is not filled with liquid	Reduce the flow / rotation speed of the motor Cool the liquid Use a filter on the suction side Fill pump with liquid
<b>Noise and vibration</b>	The pump sucks air Suction pipe is blocked Flow rate too high Loads on the pipes	Make sure all connections are tight Check pipes / valves and filters on suction line Reduce the flow / rotation speed of the motor Connect the pipes independent of the pump

### 3. MAINTENANCE

	Foreign objects in the liquid Liquid parameters different than calculated	Use a filter on the suction side Checked pumped liquid parameters
<b>Abnormal wear</b>	The pump sucks air Liquid temperature too high Loads on the pipes Foreign objects in the liquid	Make sure all connections are tight Cool the liquid Connect the pipes independent of the pump Use a filter on the suction side

#### 3.6. Disassembly of the pump

The numbers put in brackets, refer to the part numbers in the spare part drawings and spare part lists in chapter 4. "Spare parts".



The disassembly should be performed only by qualified personnel. There should always be at least two persons present during disassembly.



Each operation to be fulfilled with the machine must always be carried out once all the electrical contacts have been disconnected. The pump-motor unit must be placed in a position where it cannot be started unintentionally.



Before servicing in any way the parts that come in contact with the pumped liquid, make sure that the pump has been fully emptied and washed. When draining the liquid, make sure that there is no danger for people or the environment.

##### 3.6.1. Before the disassembly procedure



Be sure to drain all liquid from the pump. Cleanse or neutralize the pump thoroughly. Disconnect the electrical connection, air supply and then the suction and discharge connections.

# 3. MAINTENANCE

## 3.6.2. Disassembly procedure

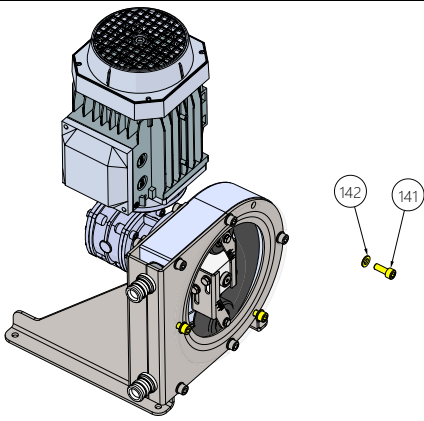
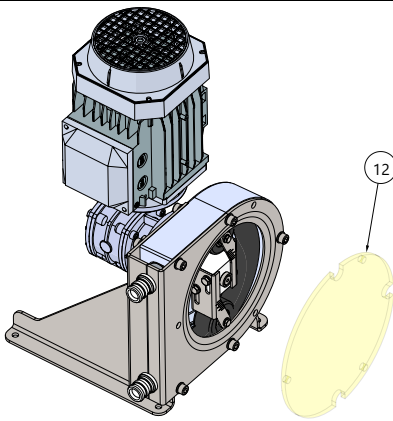
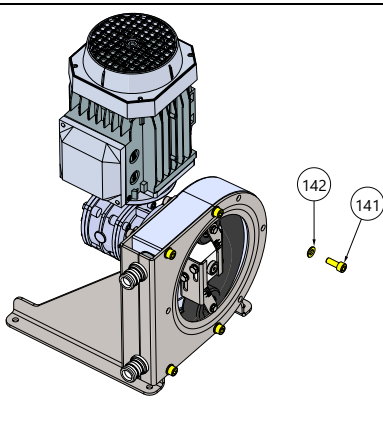
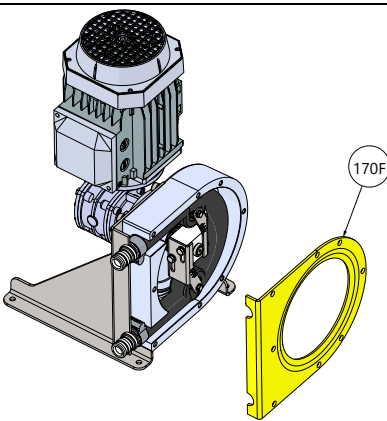
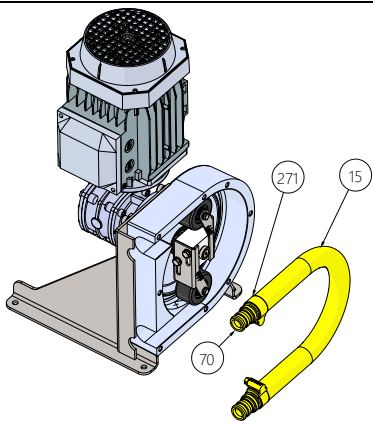
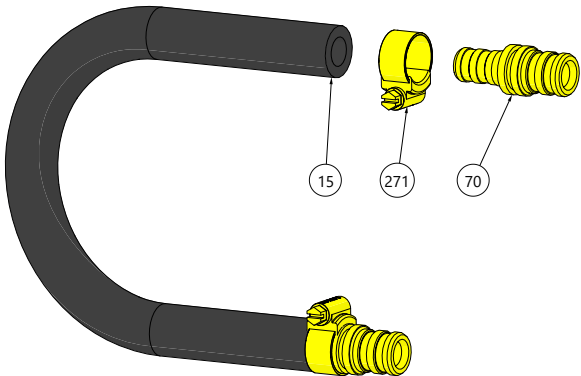
	
<p><b>Fig. 3.6.1</b> Unscrew the front cover mounting screws [141], and remove them with their washers [142].</p>	<p><b>Fig. 3.6.2</b> Remove the front cover [12].</p>
	
<p><b>Fig. 3.6.3</b> Unscrew the front connection bracket screws [141], and remove them with their washers [142].</p>	<p><b>Fig. 3.6.4</b> Remove the front connection bracket [170F].</p>
	
<p><b>Fig. 3.6.5</b> Remove the hose [15] along with the inserts [70] and clamp bands [271].</p>	<p><b>Fig. 3.6.6</b> Remove the clamp bands [271] and the inserts [70] from the hose.</p>

### 3. MAINTENANCE

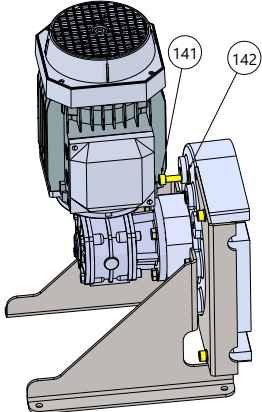
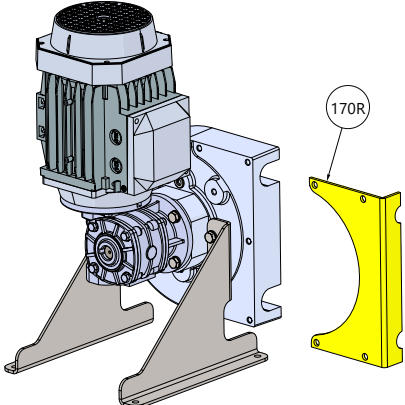
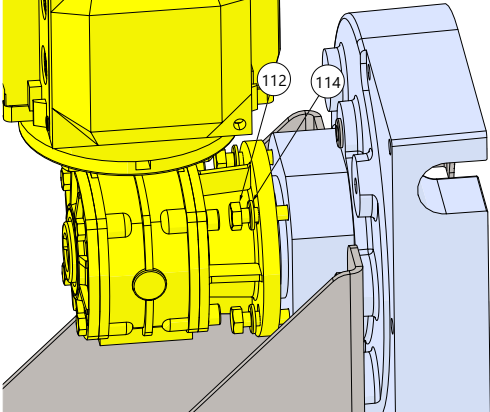
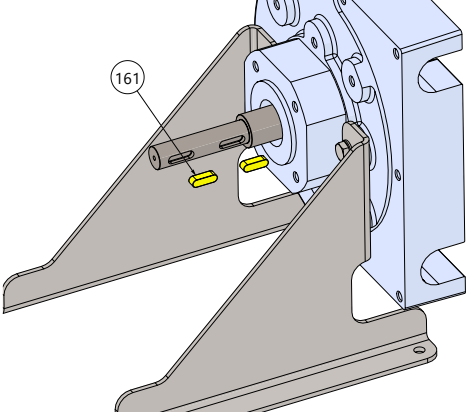
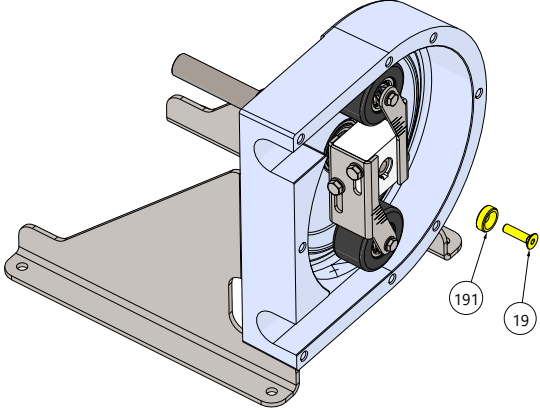
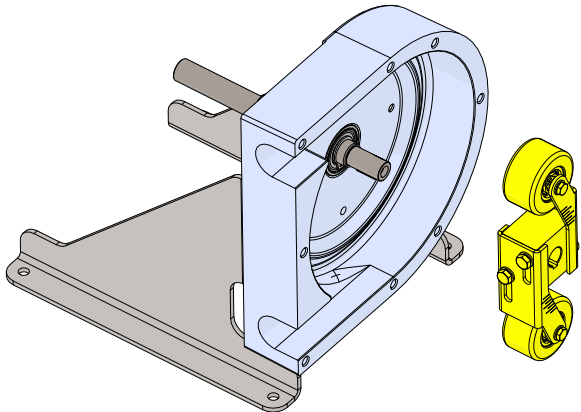
	
<p><b>Fig. 3.6.7</b> Unscrew the rear connection bracket screws [141], and remove them with their washers [142].</p>	<p><b>Fig. 3.6.8</b> Remove the rear connection bracket [170R].</p>
	
<p><b>Fig. 3.6.9</b> Unscrew the gear motor mounting bolts [112], and remove them with their washers [114].</p>	<p><b>Fig. 3.6.10</b> Remove both keys [161] from the shaft.</p>
	
<p><b>Fig. 3.6.11</b> Unscrew the shaft screw [19] and remove it with the retaining washer [191].</p>	<p><b>Fig. 3.6.12</b> Remove the complete rotor/roller assembly.</p>

### 3. MAINTENANCE

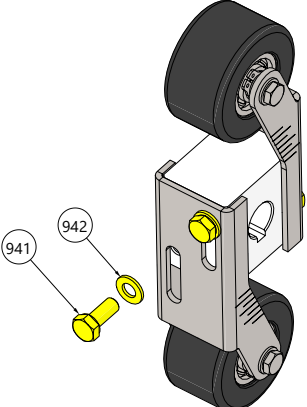
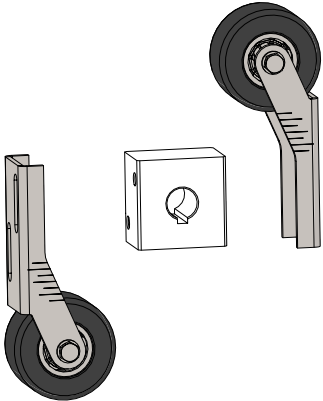
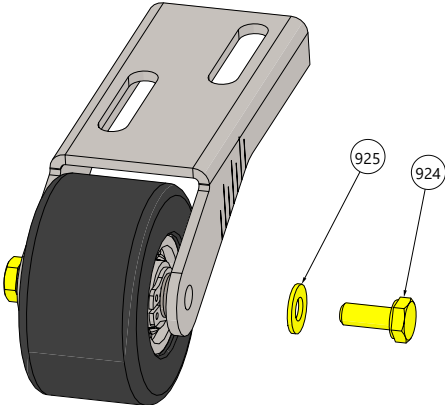
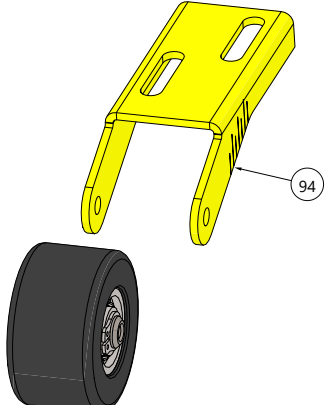
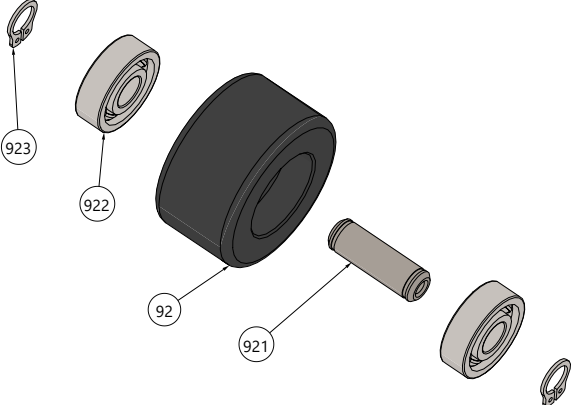
	
<p><b>Fig. 3.6.13</b> Unscrew the roller bracket mounting bolts [941] and remove them with their washers [942].</p>	<p><b>Fig. 3.6.14</b> Take of the rollers and brackets off the rotor.</p>
	
<p><b>Fig. 3.6.15</b> Unscrew the roller mounting bolts [924] and remove them with their washers [925].</p>	<p><b>Fig. 3.6.16</b> Remove the brackets [94] from the rollers.</p>
	
<p><b>Fig. 3.6.17</b> Take apart the roller assembly.</p>	

#### 3.6.3. Test run



We recommend you to conduct a test run of the pump before installing it in the system, so no liquid gets wasted if the pump leaks or perhaps does not start accordingly to wrong assembly of the pump.

**After two weeks of operation retighten the nuts with appropriate torque.**

# 3. MAINTENANCE

## 3.7. Hose cleaning

The hose can be cleaned in place without disassembly. It can be done with water or any other appropriate agent as long as it is compatible with the hose material. Check not only the chemical compatibility but also the allowable temperature for the utilized hose.

## 3.8. Hose replacement

The hose can be replaced without the whole pump disassembly. Make sure that suction and discharge valves are closed before disconnecting of the pump.

In order to avoid costly downtime of the pump, it is recommended to inspect the hose after about 90% of the lifetime of the first hose as part of preventive maintenance.

**NOTE!** Proceed with this procedure only after familiarizing oneself with the instructions at the beginning of chapter 3. *Maintenance* and all safety instruction in chapter 1.8. *Health and safety*.

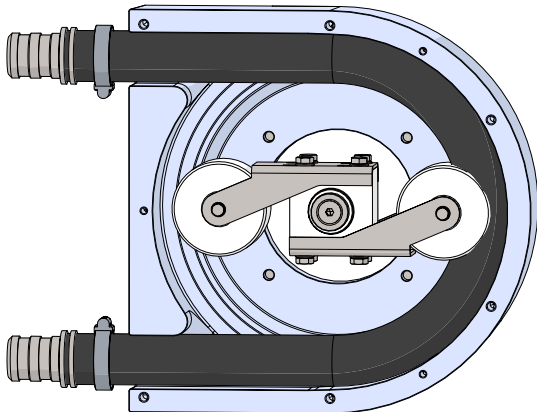
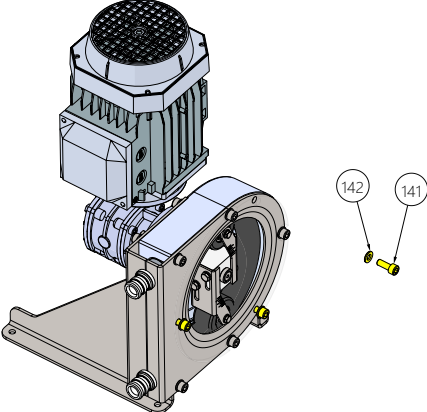
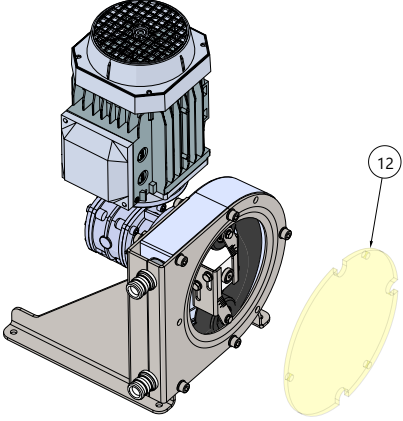
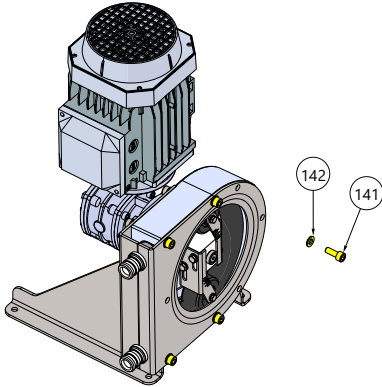
	
<p><b>Fig. 3.8.1</b> Run the pump and position the rotor so that only one roller is pressing against the hose.</p>	<p><b>Fig. 3.8.2</b> Disconnect power supply from the motor. Unscrew the front cover mounting screws [141] and remove them with their washers [142].</p>
	
<p><b>Fig. 3.8.3</b> Remove the front cover [12].</p>	<p><b>Fig. 3.8.4</b> Unscrew the front connection bracket screws [141] and remove them with their washers [142].</p>

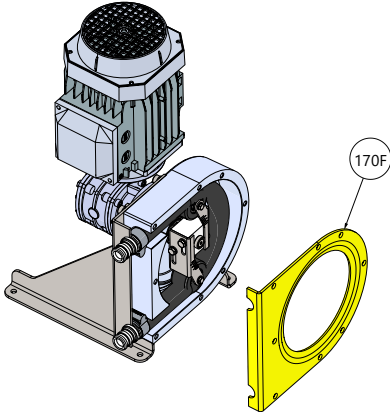
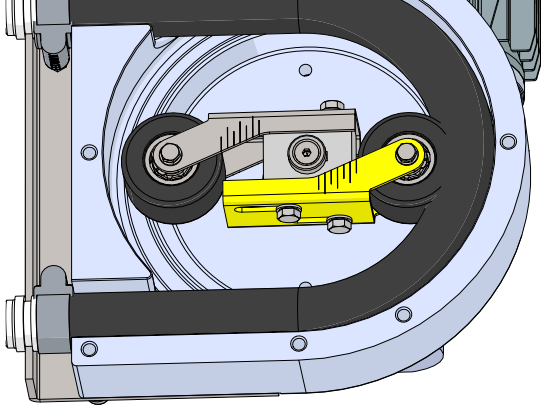
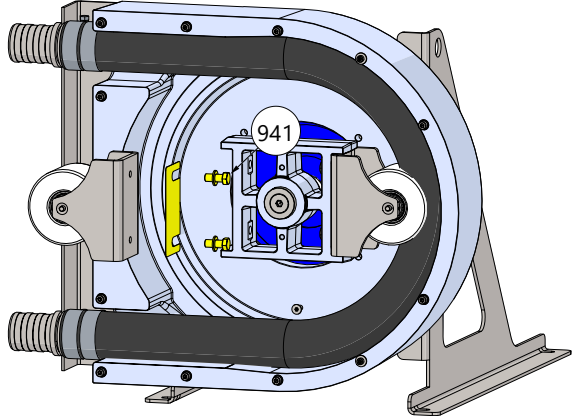
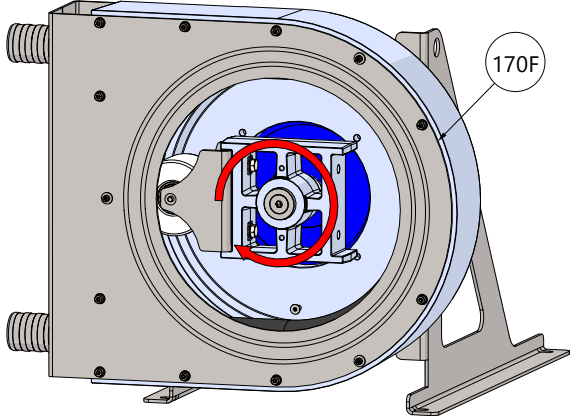

### 3. MAINTENANCE

	
<p><b>Fig. 3.8.5</b> Remove the front connection bracket [170F].</p>	<p><b>Fig. 3.8.5a PTL9 – PTL25</b> On the side where the roller IS pressing the hose, loosen the roller bracket mounting screws [941] and retract the bracket so that there is no pressure on the hose anymore. <b>NOTE!</b> Do not loosen the screws on the other side of the rotor.</p>
	
<p><b>Fig. 3.8.5b PTL30 – PTL45</b> On the side where the roller is NOT pressing the hose, remove the roller bracket mounting screws [941] and remove the roller assembly with the shims (if any).</p>	<p><b>Fig. 3.8.5c PTL30 – PTL45</b> Reassemble the front connection bracket [170F], connect power to the motor and rotate the roller 180° so that there roller is no longer pressing the hose. <b>NOTE!</b> DO NOT remove the second roller assembly.</p>

### 3. MAINTENANCE

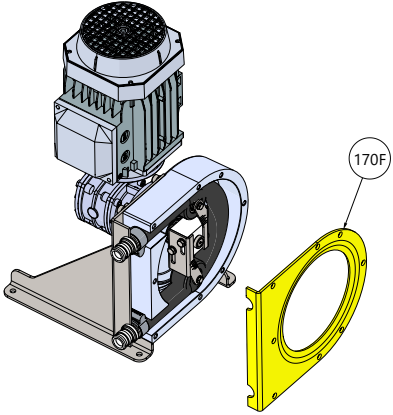
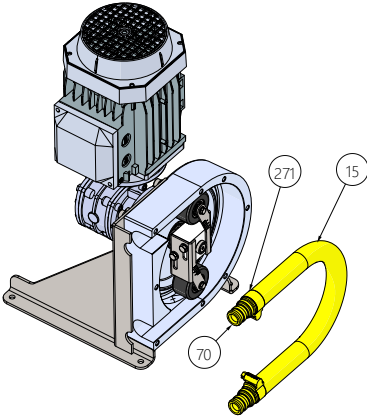
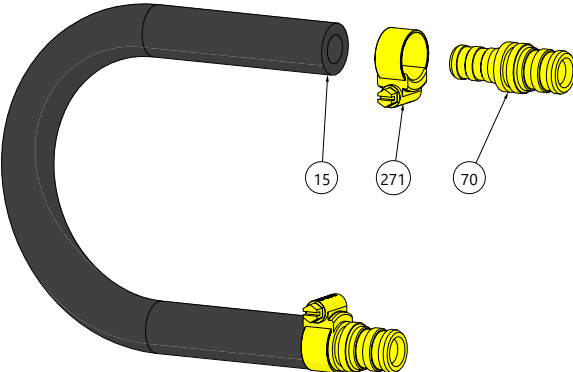
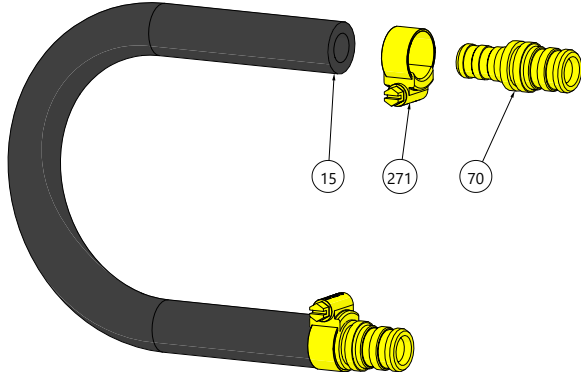
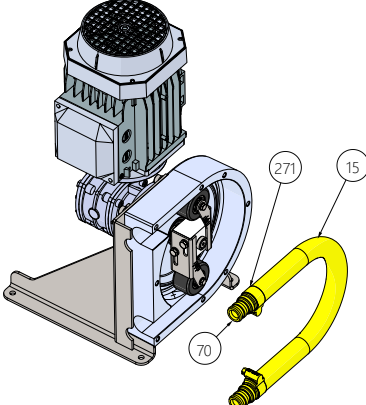
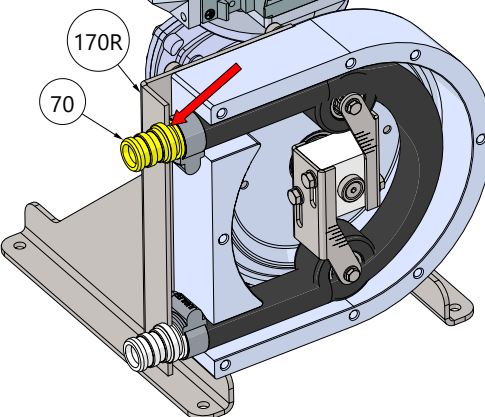
	
<p><b>Fig. 3.8.6</b> Disconnect power from the motor and once again remove the front connection bracket [170F].</p>	<p><b>Fig. 3.8.7</b> Remove the hose [15] along with the inserts [70] and clamp bands [271].</p>
	
<p><b>Fig. 3.8.8</b> Remove the clamp bands [271] and the inserts [70] from the hose. Clean the inserts [70] and pump casing [11].</p>	<p><b>Fig. 3.8.9</b> Clean the new hose [15] thoroughly before assembly. Assemble the new hose with inserts [70] and tighten the clamp bands [271].</p>
	
<p><b>Fig. 3.8.10</b> Place the hose [15] inside the pump casing.</p>	<p><b>Fig. 3.8.11</b> Align the inserts with the rear connection bracket [170R].</p>

### 3. MAINTENANCE

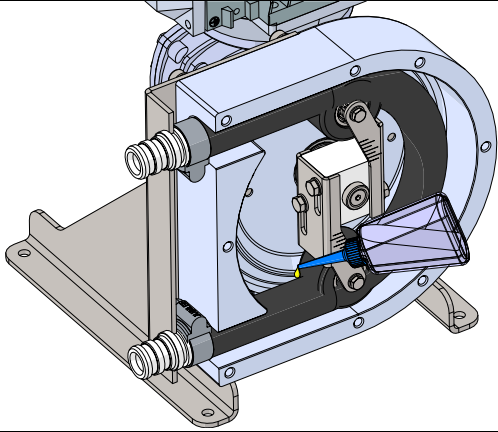
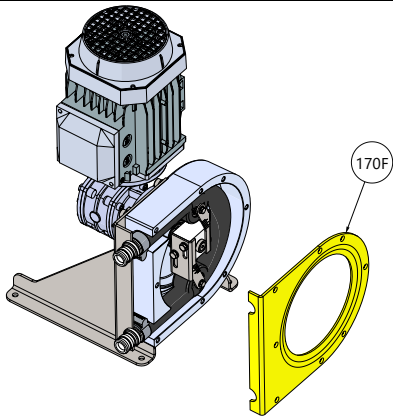
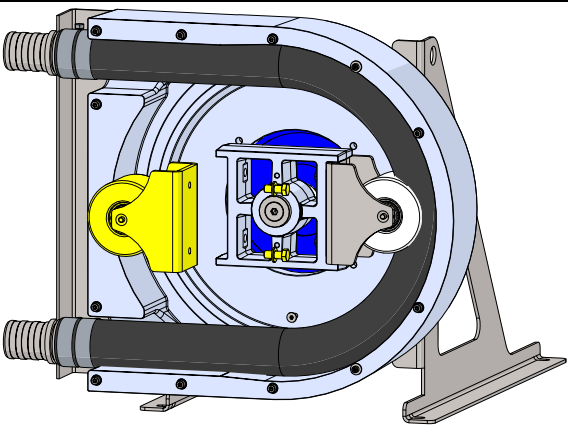
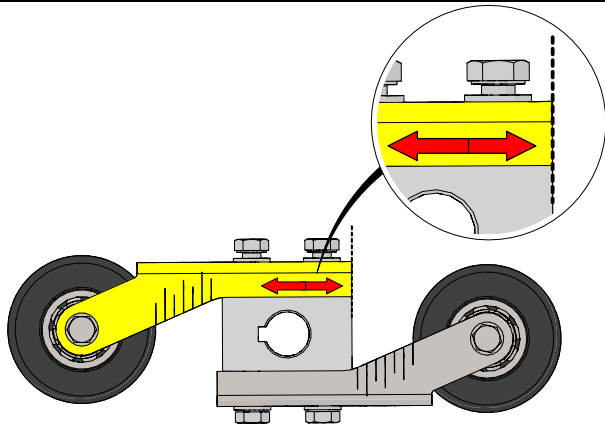
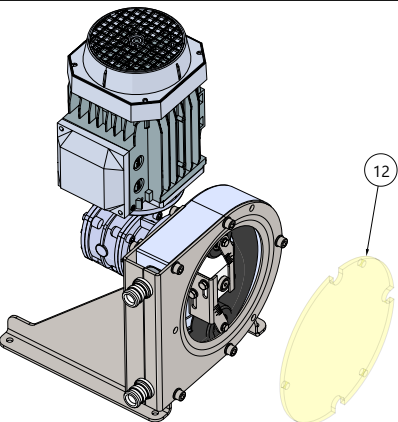
	
<p><b>Fig. 3.8.12</b> Apply lubricant on the inner surface of the hose (where the rollers run).</p>	<p><b>Fig. 3.8.13</b> Assemble the front connection bracket [170F], connect power to the motor and rotate the roller 180°.</p>
	
<p><b>Fig. 3.8.14 PTL30 – PTL45</b> Remove the cover and install the missing roller assembly without any shims.</p>	<p><b>Fig. 3.8.15</b> Set the roller pressure according to the Roller Adjustment procedure described in chapter 3.9.</p>
	
<p><b>Fig. 3.8.16</b> Assemble the front connection bracket and the front cover [12].</p>	

The hose is now re-assembled. Make sure to open the suction and discharge valves before pump start-up. Check the direction of rotation of the motor.

# 3. MAINTENANCE

## 3.9. Roller adjustment

During pump operation as the hose starts to wear, internal leakage inside the hose can occur. In order to avoid this, roller adjustment can be performed in order to increase the compression of the hose. This is an important procedure, as internal leakage reduces the hose lifetime and affect the pump flow. The adjustments vary based on pump rotation speed, discharge pressure and liquid viscosity. This operation can be done without complete pump disassembly.

**NOTE!** Proceed with this procedure only after familiarizing oneself with the instructions at the beginning of chapter 3. *Maintenance* and all safety instruction in chapter 1.8. *Health and safety*.

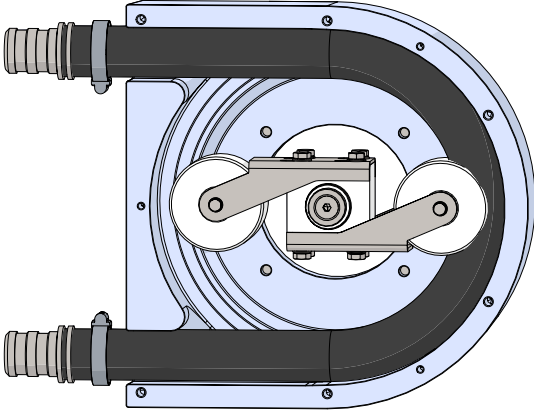
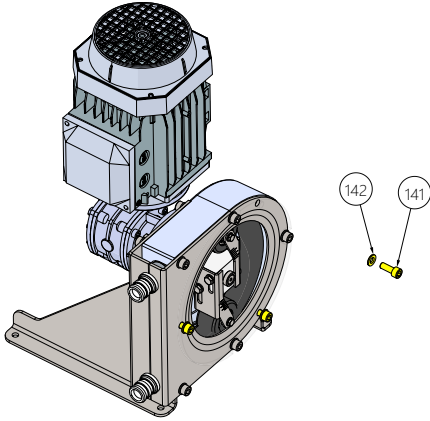
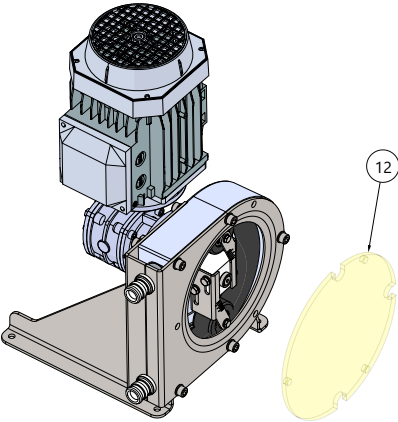
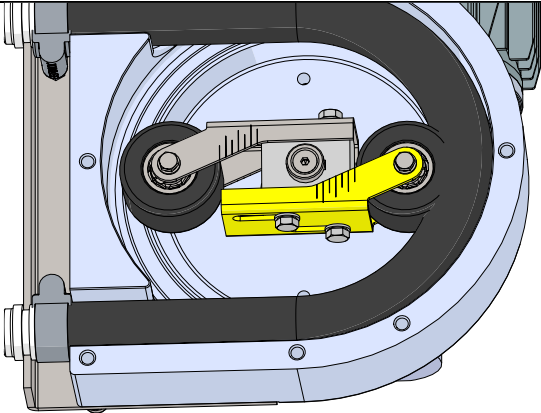
	
<p><b>Fig. 3.9.1</b> Run the pump and position the rotor so that only one roller is pressing against the hose.</p>	<p><b>Fig. 3.9.2</b> Disconnect power supply from the motor. Unscrew the front cover mounting screws [141] and remove them with their washers [142].</p>
	
<p><b>Fig. 3.9.3</b> Remove the front cover [12].</p>	<p><b>Fig. 3.9.4a PTL9 – PTL25</b> On the side where the roller IS pressing the hose, loosen the roller bracket mounting screws [941].</p>

### 3. MAINTENANCE

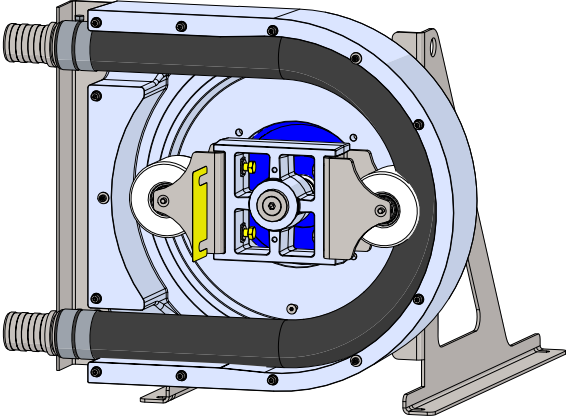
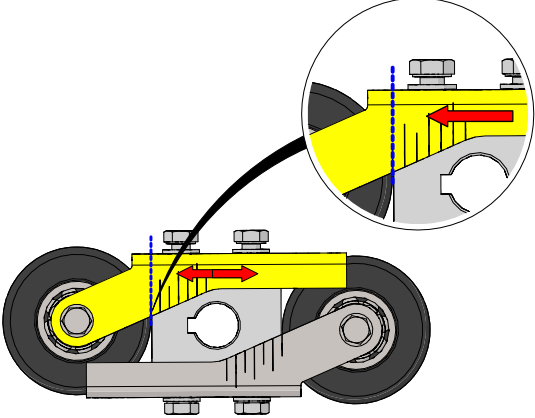
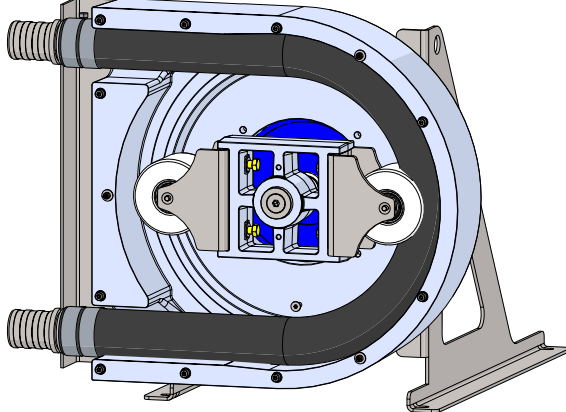
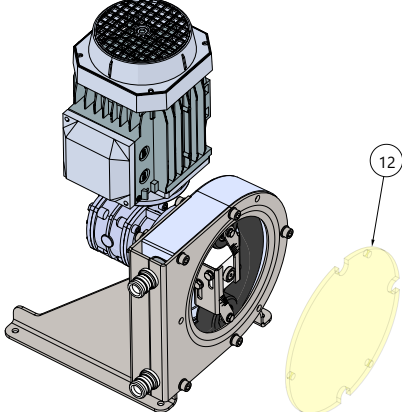
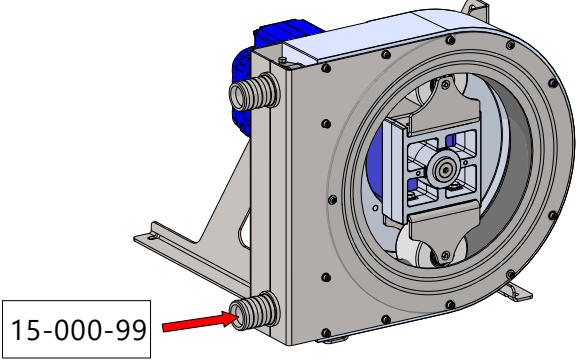
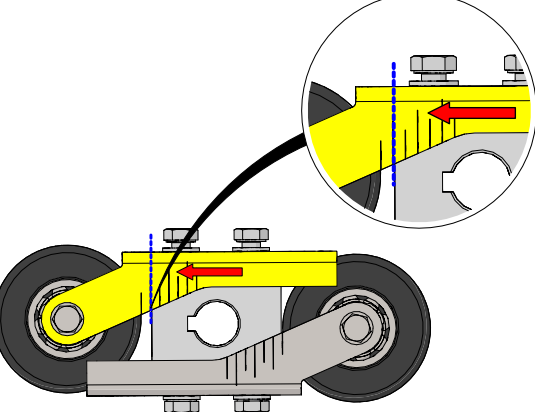
	
<p><b>Fig. 3.9.4b PTL30 – PTL45</b> Loosen the roller bracket mounting screws [941] and remove the shims [91] (if any).</p>	<p><b>Fig. 3.9.5a PTL9 – PTL25</b> On the side where the roller is not compressing the hose, adjust the roller bracket position so that the rotor is aligned with the first graduation mark on the bracket. Tighten the roller bracket mounting screws.</p>
	
<p><b>Fig. 3.9.5b PTL30 – PTL45</b> Re-tighten the roller bracket mounting screws [941].</p>	<p><b>Fig. 3.9.6</b> Reassemble the front cover [12] and run the pump.</p>
	
<p><b>Fig. 3.9.7</b> Place the vacuum gauge tool [15-000-99] on the suction insert of the pump. If the reading is (-0.6) bar or lower then further adjustment is not required.</p>	<p><b>Fig. 3.9.8a PTL9 – PTL25</b> If vacuum is not sufficient, remove the front cover again and move the bracket so the second graduation mark is in line with the rotor edge.</p>

### 3. MAINTENANCE

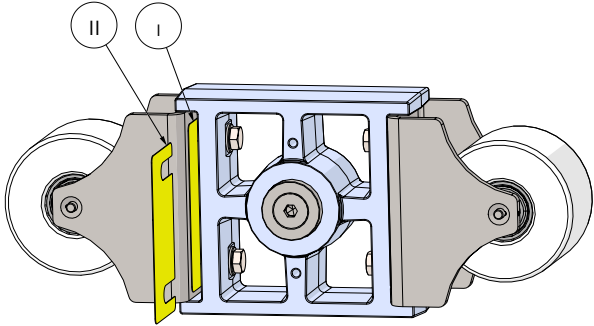
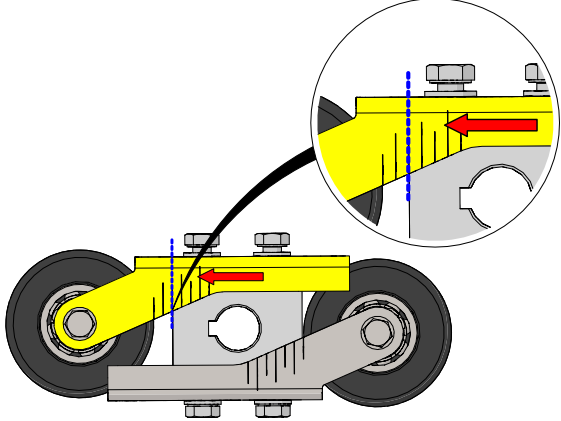
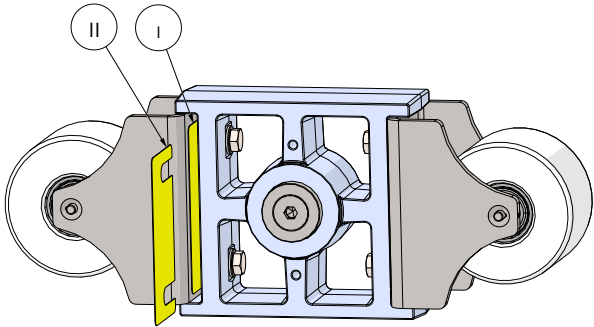
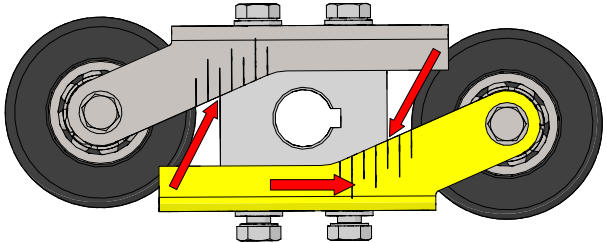
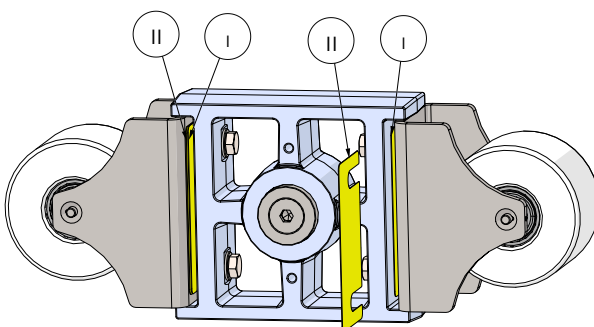
	
<p><b>Fig. 3.9.8b PTL30 – PTL45</b> If vacuum is not sufficient, remove the front cover again and add an extra 0.5 mm shim.</p>	<p><b>Fig. 3.9.9a PTL9 – PTL25</b> Repeat steps 3.9.6 and 3.9.7 and check the vacuum. Move the roller bracket to the next graduation marks as long as the vacuum reading is (-0.6) bar or lower.</p>
	
<p><b>Fig. 3.9.9b PTL30 – PTL45</b> Repeat steps 3.9.6 and 3.9.7 and check the vacuum. Add extra shims as long as the vacuum reading is (-0.6) bar or lower.</p>	<p><b>3.9.10a PTL9 – PTL25</b> Adjust the loose roller bracket to the same distance, install the front cover [12] and re-test the pump vacuum capabilities. <b>NOTE!</b> Both rollers need to be adjusted equally.</p>
	
<p><b>3.9.10b PTL30 – PTL45</b> Add the same number of shims under the second roller bracket, install the front cover [12] and re-test the pump vacuum capabilities. <b>NOTE!</b> Both rollers need to be shimmed equally.</p>	

# 4. SPARE PARTS

## 4. SPARE PARTS

Full part number consist of three parts, pump type (15 for PT pumps; 16 for PTL), pump size (e.g. 017, 045) and part position which corresponds to the number in the drawing e.g. **16-xxx-18**:

**16** – PTL low pressure hose pump

**xxx** – pump size

**18** – part position

**NOTE!** Use only Original Tapflo spare parts. Using counterfeit parts creates a risk of improper operation, increases possibility of breakdown and voids warranty terms.

### 4.1. Exploded view PTL9 – PTL17

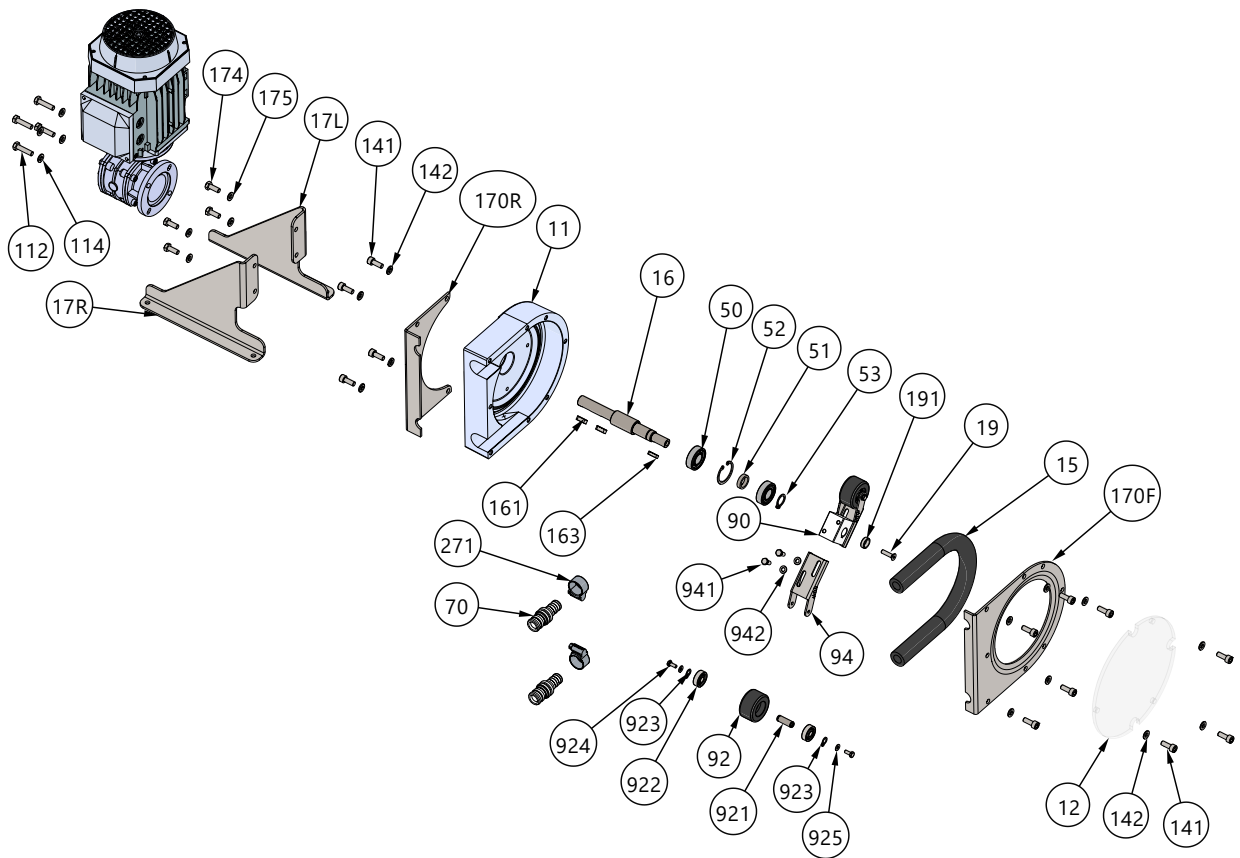

For interactive exploded view go [HERE](#)

### 4.2. Spare parts list PTL9 – PTL17

Pos.	Q-ty	Description	Material
11	1	Pump casing	Aluminium
112	4	Gearmotor mounting screw	A4-70
114	4	Gearmotor mounting washer	A4
12	1	Front cover	Polycarbonate
141	12	Bracket / front cover mounting bolt	A4-70
142	12	Bracket / front cover mounting washer	A4-70
15	1	Hose	NR, NBR, EPDM
16	1	Pump shaft	Steel

## 4. SPARE PARTS

161	2/3 <sup>2)</sup>	Shaft key	Black steel
163 <sup>1)</sup>	1	Rotor key	Black steel
17L	1	Pump foot – left	Galvanized steel
17R	1	Pump foot – right	Galvanized steel
170F	1	Connection bracket - front	Galvanized steel
170R	1	Connection bracket - rear	Galvanized steel
174	4	Casing mounting bolt	A4-70
175	4	Casing mounting washer	A4-70
19	1	Shaft screw	A4-70
191	1	Retaining washer	AISI 304L
271	2	Clamp band	AISI 316L
50	2	Bearing	Steel
51	1	Distance sleeve	Steel
52	1	Shaft circlip – big	Zinc plated steel
53	1	Shaft circlip - small	Zinc plated steel
70	2	Hose insert	AISI 316L, PTFE
90	1	Rotor	Aluminium
92	2	Roller	Polyamide
921	2	Roller shaft	Steel
922	4	Roller bearing	Steel
923	4	Roller circlip	Zinc plated steel
924	4	Roller mounting screw	A4-70
925	4	Roller mounting washer	A4-70
94	2	Roller bracket	Galvanized steel
941	4	Roller bracket mounting bolt	A4-70
942	4	Roller bracket mounting washer	A4-70

- 1) Only for PTL9 and PTL13
- 2) **2** for PTL9 and PTL1313 / **3** for PTL17



## 4. SPARE PARTS

### 4.3. Exploded view PTL25 – PTL45

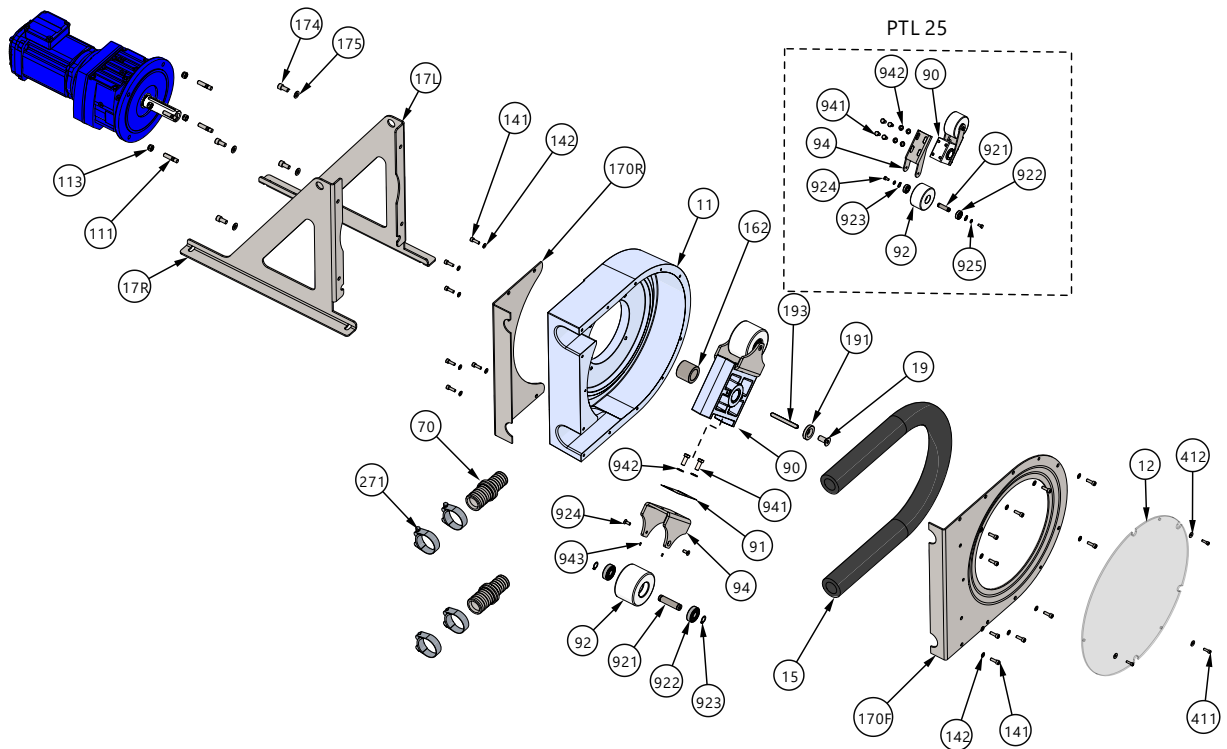

For interactive exploded view go [HERE](#)

### 4.4. Spare parts list PTL25 – PTL45

Pos.	Q-ty	Description	Material
11	1	Pump casing	Aluminium
111	4	Gearmotor mounting stud bolts	A4-70
113	4	Gearmotor mounting nuts	A4
12	1	Front cover	Polycarbonate
141	11/16 <sup>3</sup>	Bracket mounting bolt	A4-70
142	11/16 <sup>3</sup>	Bracket mounting washer	A4-70
15	1	Hose	NR, NBR, EPDM
162	1	Shaft sleeve	Steel
17L	1	Pump foot – left	Galvanized steel
17R	1	Pump foot – right	Galvanized steel
170F	1	Connection bracket - front	Galvanized steel
170R	1	Connection bracket - rear	Galvanized steel
174	4	Casing mounting bolt	A4-70
175	4	Casing mounting washer	A4-70
19	1	Shaft screw	A4-70
191	1	Retaining washer	AISI 304L
193	1	Rotor key	Carbon steel
271	2/4 <sup>1</sup>	Clamp band	AISI 316L
411	3	Front cover mounting bolt	A4-70
412	3	Front cover mounting washer	A4-70

## 4. SPARE PARTS

70	2	Hose insert	AISI 316L, PTFE
90	1	Rotor	Aluminium
91 <sup>5)</sup>	8	Shim	AISI 304L
92	2	Roller	Aluminium
921	2	Roller shaft	Steel
922	4	Bearing	Steel
923	4	Circlip	Zinc plated steel
924	4	Roller mounting screw	A4-70
925 <sup>2)</sup>	4	Roller mounting washer	A4-70
94	2	Roller bracket	Galvanized steel
941	8/4 <sup>4)</sup>	Roller bracket mounting bolt	A4-70
942	8/4 <sup>4)</sup>	Roller bracket mounting washer	A4-70
943 <sup>5)</sup>	4	Roller bracket grub screw	A4

- 1) **2** for PTL25 / **4** for PTL30 and PTL45
- 2) Only PTL25
- 3) **11** for PTL25 / **16** for PTL30 and PTL45
- 4) **8** for PTL25 / **4** for PTL30 and PTL45
- 5) Only for PTL30 and PTL45

### 4.5. Stocking recommendation

Even at normal operation some elements in the pump will be worn. In order to avoid expensive breakdowns we recommend having a few spare parts in stock as a minimum:

Pos.	Description	Q-ty
15	Hose	2-3*
91	Shim	8

\* Depending on the application conditions it is recommended to keep 2 to 3 hoses on stock.

Tapflo also offers **spare parts KITS** for the PTL pumps:

- Rotor spare parts KIT: **KIT ROTOR PTL9/13, KIT ROTOR PTL17, KIT ROTOR PTL25**

Pos.	Description	Q-ty
90	Rotor	1
92	Roller	2
94	Roller bracket	2
921	Roller shaft	2
922	Roller bearing	4
923	Roller circlip	4
924	Roller mounting screw	4
925	Roller mounting washer	4
941	Roller bracket bolt	4/8*
942	Roller bracket washer	4/8*

\* **4** for PTL9 – PTL17 / **8** for PTL25

## 4. SPARE PARTS

---

- Shaft spare parts KIT: **KIT SHAFT PTL9/13, KIT SHAFT PTL17,**

Pos.	Description	Q-ty
16	Shaft	1
161	Shaft key	2/0*
163	Rotor key	1/3**
19	Shaft screw	1
191	Retaining washer	1
50	Roller bearing – shaft	2
51	Distance sleeve	1
52	Shaft circlip – large	1
53	Shaft circlip – small	1

\* **2** for PTL9/13 / **0** for PTL17

\* **1** for PTL9/13 / **3** for PTL17

### 4.6. How to order parts

When ordering spare parts for Tapflo pumps, please let us know what is the **model number** and **serial number** from the pump centre body or housing. Then just indicate the part numbers from the spare parts list and quantity of each item.

# 4. SPARE PARTS

## 4.7. Pump code

The model number on the pump and on the front page of this instruction manual tells the pump size and materials of the pump.

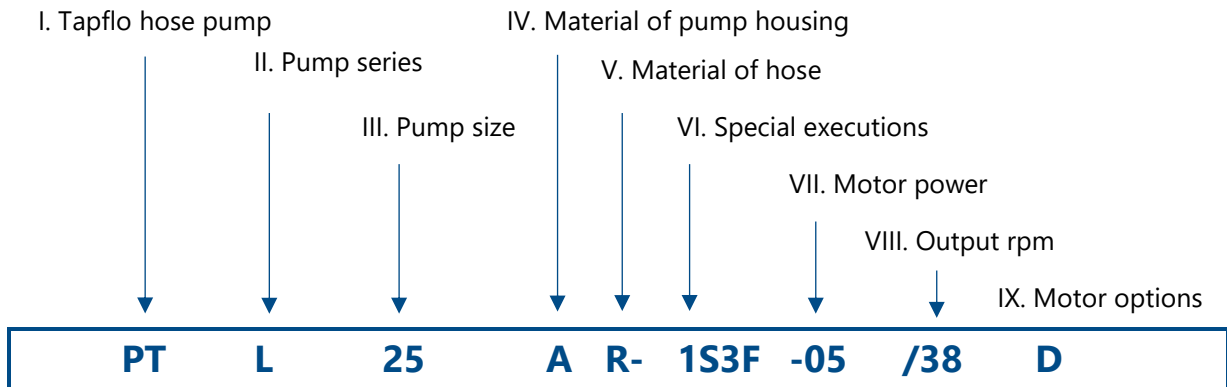

- I. PT = Tapflo hose pump
- II. Pump series:
  - blank* = High pressure pumps
  - L = Low pressure pumps
- III. Pump size = Hose inner diameter
- IV. Material of pump housing:
  - A = Aluminium (**standard**)
- V. Material of hose:
  - E = EPDM
  - N = NBR (nitrile rubber)
  - R = NR (**standard**)
  - W = EPDM FDA
  - S = NR FDA
  - F = NBR FDA
- VI. Special executions:
  - 1 = Optional insert material
    - S = AISI 316L (**standard**)
    - T = PTFE
    - P = PE AST
    - L = PP
  - 2 = Inlet/outlet direction (looking from pump head side)
    - L = Left (**standard**)
    - R = Right
    - U = Up
    - D = Down
- 3 = Optional connection type
  - A = ANSI/ASME B16.5 Class 150 Flange
  - B = BSP male thread
  - C = SMS 3017 clamp
  - F = EN 1092-1 flange
  - H = Hose tail (**standard**)
  - T = DIN 32676 clamp
- 5 = Other special executions
  - L = Hose leak detection system
  - T = 3-lobe rotor (standard on PT5)
- 6 = Optional flange bracket material
  - blank* = Galvanized steel
  - S = AISI 304L stainless steel
- VII. Motor power
  - 01 = 0.18 kW
  - 02 = 0.25 kW
  - 03 = 0.37 kW
  - 05 = 0.55 kW
  - 07 = 0.75 kW
  - 11 = 1.1 kW
  - 15 = 1.5 kW
  - 22 = 2.2 kW
- VIII. Output rpm
- IX. Motor options
  - C = External cooling fan
  - D = Built on frequency inverter
  - A = Angle reducer

# 5. DATA

## 5. DATA

### 5.1. Capacity curves

The performance curves are based on water at 20°C. Other circumstances might change the performance. See below how the capacity will change at different viscosities and suction lifts. Intermittent duty = 1 hour stop for every 2 hours of operation. Occasional duty = not more than 1 hour per day.

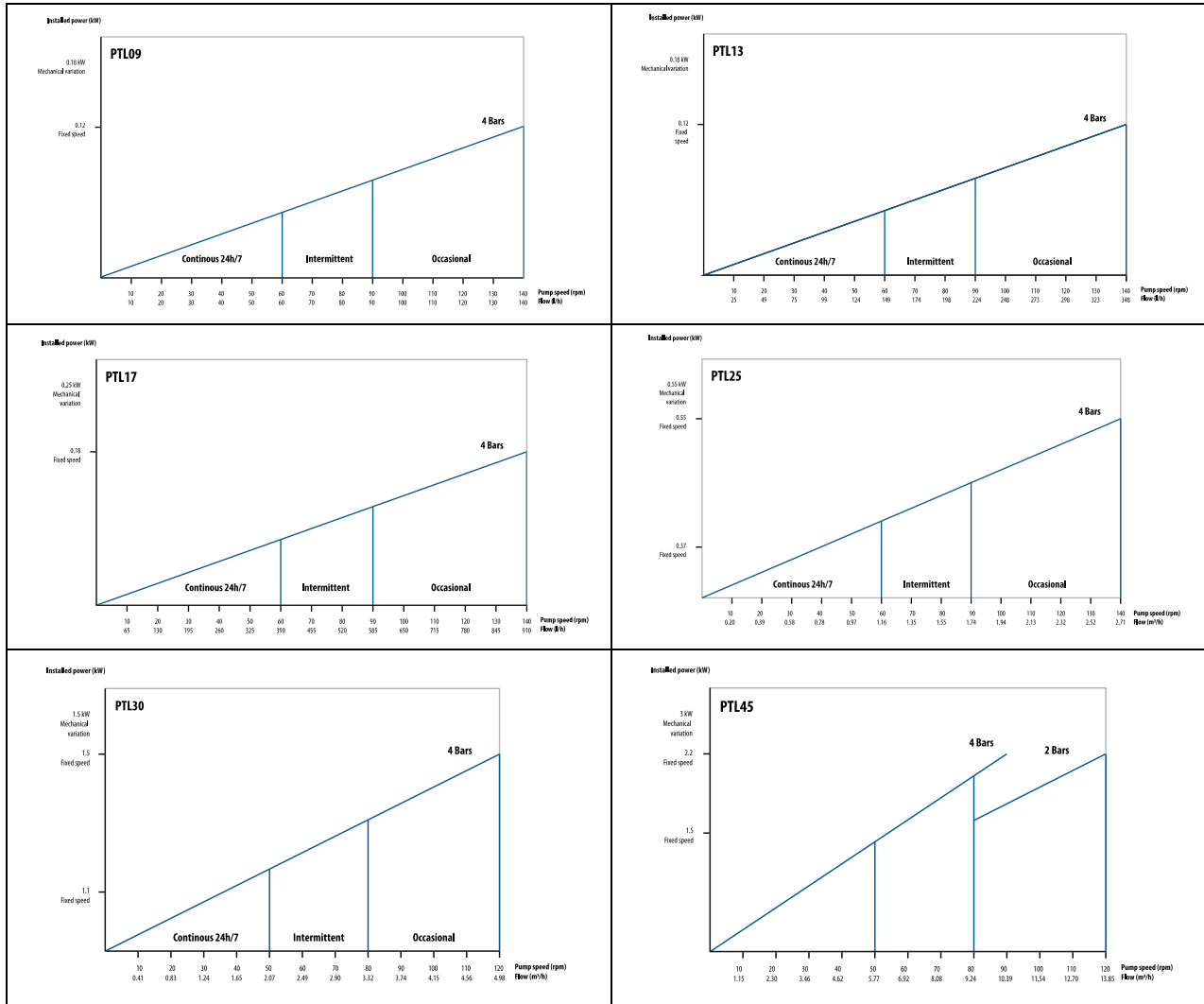

# 5. DATA

## 5.2. Technical data

TECHNICAL DATA	PUMP TYPE					
	PTL9	PTL13	PTL17	PTL25	PTL30	PTL45
Max capacity @ 50 Hz [m <sup>3</sup> /h] / [US GPM]	0.07 / 0.31	0.34 / 1.50	0.90 / 3.96	2.78 / 12.24	4.27 / 18.80	10.62 / 46.8
Max discharge pressure [bar] / [psi]	4 / 58	4 / 58	4 / 58	4 / 58	4 / 58	4 / 58
Max suction lift [m] / [Ft]	9 / 30	9 / 30	9 / 30	9 / 30	9 / 30	9 / 30
Maximum pump speed [rpm @ 50 Hz]	69	138	138	143	103	92
Max liquid temperature* [°C] / [°F]	80 / 176	80 / 176	80 / 176	80 / 176	80 / 176	80 / 176
Max viscosity [cP]	20000	20000	20000	20000	20000	20000
Weight with biggest gearmotor [kg] / [lb]	9.2 / 20	9 / 20	35 / 77	35 / 77	35 / 77	80 / 176

\* Max temperature can depend on hose material utilized in the pump.

# 5. DATA

## 5.3. Dimensions

Dimensions in mm (where other is not indicated)

Dimensions in inch (where other is not indicated)

General dimensions only, ask us for detailed drawings. Changes reserved without notice.

### 5.3.1. PTL9 – PTL17

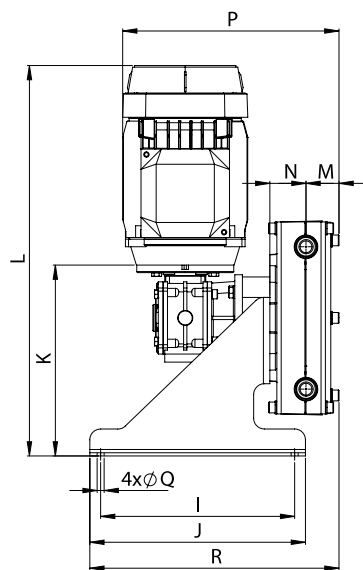
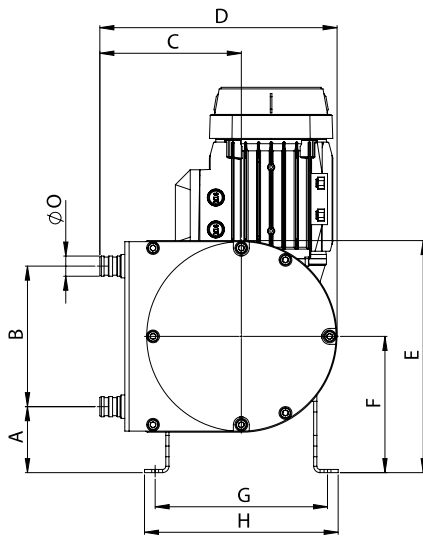

	PUMP SIZE		
	PTL9	PTL13	PTL17
A	62 2.44	62 2.44	71 2.80
B	132 5.20	132 5.20	188 7.40
C	133 5.24	133 5.24	188 7.40
D	223 8.78	223 8.78	312 12.28
E	218 8.58	218 8.58	289 11.38
F	128 5.04	128 5.04	165 6.50
G	162 6.38	162 6.38	220 8.66
H	182 7.17	182 7.17	244 9.61
I	180 7.09	180 7.09	180 7.09
J	200 7.87	200 7.87	200 7.87
K	177 6.97	177 6.97	236 9.29
L	362 14.25	362 14.25	421 16.57
M	20 0.79	20 0.79	35 1.38
N	31 1.22	31 1.22	40 1.57
ØO	16 0.63	19 0.75	25 1
P	201 7.91	201 7.91	244.5 9.63
ØQ	4 x 6.5 4 x 0.26	4 x 6.5 4 x 0.26	4 x 7 4 x 0.28
R	231 9.09	231 9.09	243 9.57

# 5. DATA

## 5.3.2. PTL25 – PTL45

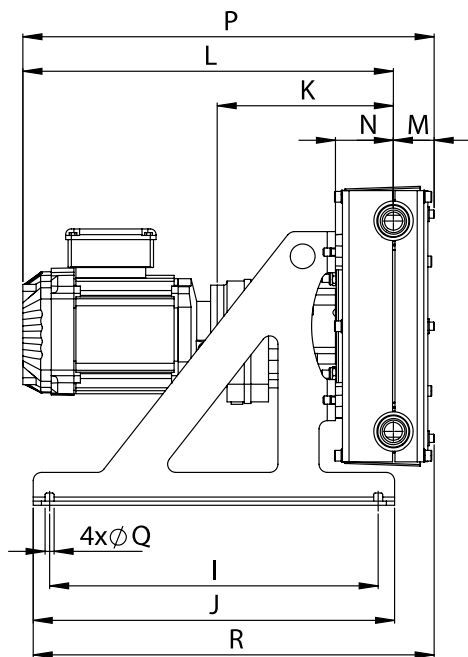
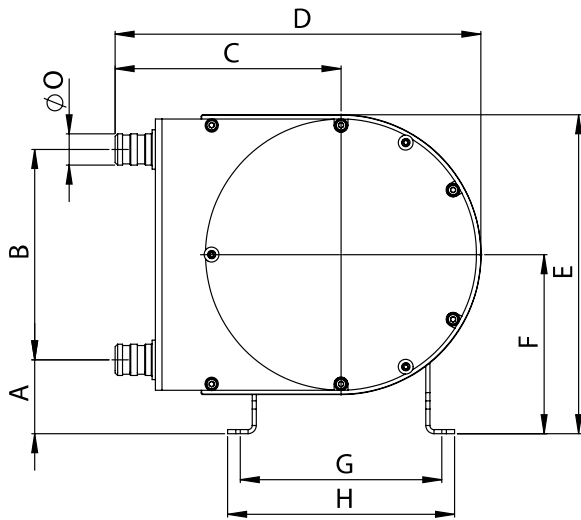

	PUMP SIZE		
	PTL25	PTL30	PTL45
A	90	152	104
	3.54	5.98	4.09
B	256	355	438
	10.08	13.9	17.24
C	275	350	453.5
	10.83	13.78	17.85
D	445	578	748.5
	17.52	22.76	29.47
E	388	562	627
	15.28	22.13	24.69
F	218	334	332
	8.58	13.15	13.07
G	245	343	425
	9.65	13.50	16.73
H	276	402	483
	10.87	15.83	19.02
I	400	550	650
	15.75	21.65	25.59
J	440	590	700
	17.32	23.23	27.56
K	214.5	249.5	311
	8.44	9.82	12.24
L	451	526	613
	17.76	20.71	24.13
M	50	58	77
	1.97	2.28	3.03
N	70.5	79.5	91
	2.78	3.13	3.58
ØO	38	45.2	60
	1.50	1.78	2.36
P	501	584	690
	19.72	22.99	27.17
ØQ	4 x 11	4 x 14	4 x 14
	4 x 0.43	4 x 0.55	4 x 0.55
R	488	652	780
	19.21	25.67	30.71



# 5. DATA

## 5.4. Tightening torques

Checking of the tightening torques is necessary after all periods of stoppage, when temperature variations are a factor and after all transport and maintenance of the pump. What is more, for proper operation and safety the torque values should be checked frequently as part of preventive maintenance (please contact Tapflo for interval proposals). Although pump applications vary, a general guideline is to re-torque the pump every two weeks.

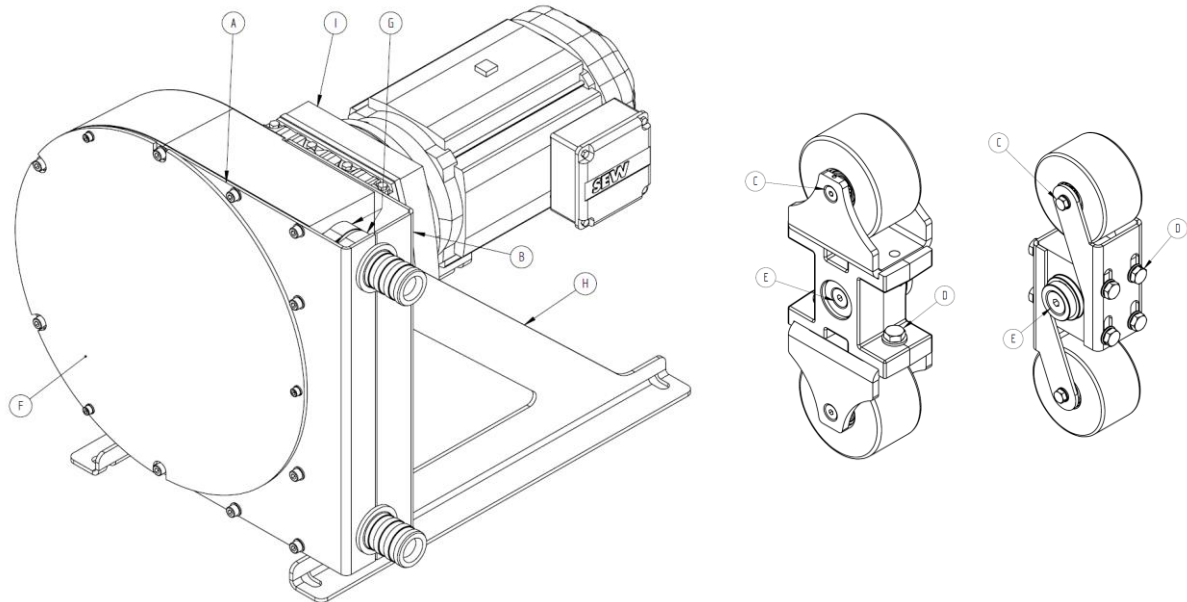

Item	Bolt pos.	Name	TPRQUE [Nm]				
			PTL9-13	PTL17	PTL25	PTL30	PTL45
A	141	Connection bracket - front	15	15	22	24	26
B	141	Connection bracket - rear	15	15	22	24	26
C	924	Roller	5	12	25	45	45
D	941	Bracket	7	16	25	55	55
E	19	Shaft	5	5	55	55	80
F	411	Front cover	3.3	3.3	3.3	3.3	3.3
G	271	Clamp band	4	20	4	20	20
H	174	Casing	15	26	30	50	50
I	112	Gear motor	20	30	50	60	70

# 5. DATA

## 5.5. Permitted loads on manifolds

We recommend not to exceed the following loads and forces reacting on the manifolds.

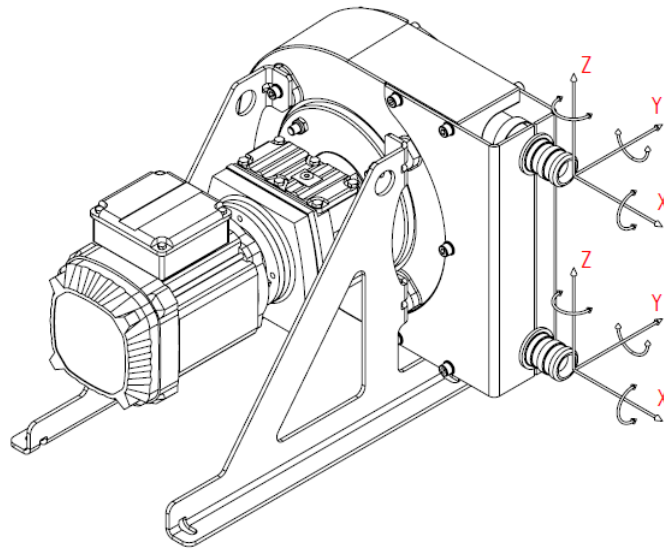

Pump size	Direction	Load [Nm]	Force [Nm]
PTL9 – PTL13	X	110	-
	Y	90	5
	Z	85	5
PTL17	X	330	-
	Y	160	5
	Z	80	5
PTL25	X	240	-
	Y	180	10
	Z	210	15
PTL30	X	290	-
	Y	200	15
	Z	180	25
PTL45	X	280	-
	Y	190	20
	Z	140	30



## 6. WARRANTY

---

### 6.2. Returning parts

When returning parts to Tapflo please follow this procedure:

- Consult Tapflo for shipping instructions.
- Cleanse or neutralize and rinse the part/pump. Make sure the part/pump is completely empty from liquid.
- Pack the return articles carefully to prevent any damage during transportation.

***Goods will not be accepted unless the above procedure has been complied with.***

### 6.3. Warranty

Tapflo warrants products under conditions as stated below for a period of not more than 5 years from installation and not more than 6 years from date of manufacturing.

1. The following terms and conditions apply to the sale of machinery, components and related services and products, of Tapflo (hereinafter "the products").
2. Tapflo (the manufacturer) warrants that:
  - a. its products are free of defects in material, design and workmanship at the time of original purchase;
  - b. its products will function in accordance with Tapflo operative manuals; Tapflo does not guarantee that the product will meet the precise needs of the Customer, except for those purposes set out in any invitation to render documents or other documents specifically made available to Tapflo before entering into this agreement;
  - c. high quality materials are used in the construction of the pumps and that machining and assembly are carried out to the highest standards.

Except as expressly stated above, Tapflo makes no warranties, express or implied, concerning the products, including all warranties of fitness for a particular purpose.

3. This warranty shall not be applicable in circumstances other than defects in material, design, and workmanship. In particular warranty shall not cover the following:
  - a. Periodic checks, maintenance, repair and replacement of parts due to normal wear and tear (seals, O-rings, rubber items, diaphragms, air valves etc.);
  - b. Damage to the product resulting from:
    - b.1. Tampering with, abuse or misuse, including but not limited to failure to use the product for its normal purposes as stated at the time of purchase or in accordance with Tapflo instructions for use and maintenance of the product, or the installation or improper ventilation or use of the product in a manner inconsistent with the technical or safety standard in force;
    - b.2. Repairs performed by non-skilled personnel or use of non-original Tapflo parts;
    - b.3. Accidents or any cause beyond the control of Tapflo, including but not limited to lightning, water, fire, earthquake, and public disturbances, etc.;

## 6. WARRANTY

---

4. The warrantee shall cover the replacement or repairing of any parts, which is documented faulty due to construction or assembling, with new or repaired parts free of charges delivered by Tapflo. Parts subjected to normal tear and wear shall not be covered by the warranty. Tapflo shall decide as to whether the defective or faulty part shall be replaced or repaired.
5. The warrantee of the products shall be valid for a period in accordance to the current law from the date of delivery, under the condition that notice of the alleged defect to the products or parts thereof be given to Tapflo in written within the mandatory term of 8 days from the discovery. Repair or replacement under the terms of this warranty shall not give a right to an extension to, or a new commencement of, the period of warranty.
6. Repair or replacement under the terms of this warranty shall not give a right to an extension to, or a new commencement of, the period of warranty. Repair or replacement under the terms of this warranty may be fulfilled with functionally equivalent reconditioned units. Tapflo qualified personnel shall be solely entitled to carry out repair or replacement of faulty parts after careful examination of the pump. Replaced faulty parts or components will become the property of Tapflo.
7. The products are built in accordance with standard CE normative and are tested (where applicable) by Tapflo. Approval and tests by other control authority are for the customer's account. The products shall not be considered defective in materials, design or workmanship if they need to be adapted, changed or adjusted to conform to national or local technical or safety standards in force in any country other than that for which the unit was originally designed and manufactured. This warranty shall not reimburse such adaptations, changes or adjustments, or attempt to do so, whether properly performed or not, nor any damage resulting from them, nor any adaptation, change or adjustments to upgrade the products from their normal purpose as described in the products operative manual without the prior written consent of Tapflo.
8. Installation, including electric and other connections to utility mains according to Tapflo drawings, is for the cost and responsibility of the customer, unless otherwise agreed in writing.
9. Tapflo will not be liable on any claim, whether in contract, tort, or otherwise, for any indirect, special, incidental, or consequential damages, caused to the customer or to third parties, including loss of profits, arising by any possible infringement of par. 3 above or by the customer or third parties being in the impossibility of using the products.

Steady the above, Tapflo liability to the customer or third parties from any claim, whether in contract, tort, or otherwise, shall be limited to the total amount paid by the customer for the product that caused the damages.

## Sweden

Filaregatan 4 | S-442 34 Kungälv

Tel: +46 303 63390

Fax: +46 303 19916

E-mail addresses:

Commercial questions: [sales@tapflo.com](mailto:sales@tapflo.com)

Orders: [order@tapflo.com](mailto:order@tapflo.com)

Tech support: [support@tapflo.com](mailto:support@tapflo.com)

## Tapflo products and services are available worldwide.

Tapflo is represented by own Tapflo Group Companies and carefully selected distributors assuring highest Tapflo service quality for our customers' convenience.

AUSTRALIA | AUSTRIA | AZERBAIJAN | BAHRAIN | BELARUS | BELGIUM | BOSNIA & HERZEGOVINA | BRAZIL | BULGARIA | CANADA | CHILE | CHINA | COLOMBIA | CROATIA | CZECH REPUBLIC | DENMARK | ECUADOR | EGYPT | ESTONIA | FINLAND | FRANCE | GEORGIA | GERMANY | GREECE | HONG-KONG | HUNGARY | ICELAND | INDIA | INDONESIA | IRELAND | ISRAEL | ITALY | JAPAN | JORDAN | KAZAKHSTAN | KUWAIT | LATVIA | LIBYA | LITHUANIA | MACEDONIA | MALAYSIA | MEXICO | MONTENEGRO | MOROCCO | NETHERLANDS | NEW ZEALAND | NORWAY | POLAND | PORTUGAL | PHILIPPINES | QATAR | ROMANIA | RUSSIA | SAUDI ARABIA | SERBIA | SINGAPORE | SLOVAKIA | SLOVENIA | SOUTH AFRICA | SOUTH KOREA | SPAIN | SWEDEN | SWITZERLAND | TAIWAN | THAILAND | TURKEY | UKRAINE | UNITED ARAB EMIRATES | UNITED KINGDOM | USA | UZBEKISTAN | VIETNAM

## Tapflo Group Companies

### Australia

Tapflo Oceania (Pty) Ltd  
Tel: +61 1800 303 633  
[sales@tapflo.com.au](mailto:sales@tapflo.com.au)

### Austria

Tapflo Austria  
Tel: +43 732 27292910  
[sales@tapflo.at](mailto:sales@tapflo.at)

### Baltic States

Tapflo Latvia  
Tel: +371 67472205  
[sales@tapflo.lv](mailto:sales@tapflo.lv)

### Belarus

Tapflo Belarus  
Tel: +375 17 3934609  
[sales@tapflo.by](mailto:sales@tapflo.by)

### Belgium

Tapflo Benelux B.V.  
Tel: +31 (0)85 00 743 00  
[info@tapflo.nl](mailto:info@tapflo.nl)

### Bulgaria

Tapflo EOOD  
Tel: +359 (0)2 974 18 54  
[office@tapflo.bg](mailto:office@tapflo.bg)

### Canada

Tapflo Canada  
Tel: +1 514 813 5754  
[canada@tapflo.com](mailto:canada@tapflo.com)

### Croatia

Tapflo d.o.o.  
Tel: +385 91 4884 666  
[sales@tapflo.hr](mailto:sales@tapflo.hr)

### Czech Republic

Tapflo s.r.o.  
Tel: +420 513 033 924  
[tapflo@tapflo.cz](mailto:tapflo@tapflo.cz)

### China

Tapflo (Wuxi)  
Tel: +86 510 8241 7072  
[sales@tapflo.cn](mailto:sales@tapflo.cn)

### Denmark

Tapflo Danmark  
Tel: +45 36 454600  
[info@tapflo.dk](mailto:info@tapflo.dk)

### France

Tapflo France  
Tel: +33 1 34 78 82 40  
[info@tapflo.fr](mailto:info@tapflo.fr)

### Hungary

Tapflo kft.  
Tel: +36 30 148 8551  
[office@tapflo.hu](mailto:office@tapflo.hu)

### India

Tapflo Fluid Handling India Pvt Ltd  
Tel: +91 20 65000215  
[ac@tapflo.in](mailto:ac@tapflo.in)

### Ireland

Tapflo Ireland Ltd  
Tel: +353 1 2011911  
[info@tapflo.ie](mailto:info@tapflo.ie)

### Italy

Tapflo Italia  
Tel: +39 0362307698  
[info@tapfloitalia.com](mailto:info@tapfloitalia.com)

### Japan

Tapflo Japan K.K.  
Tel: +81-3-6240-3510  
[tapflojp@tapflo.co.jp](mailto:tapflojp@tapflo.co.jp)

### Kazakhstan

Tapflo Kazakhstan  
Tel: +7 727 3278347  
[sales@tapflo.kz](mailto:sales@tapflo.kz)

### Netherlands

Tapflo Benelux B.V.  
Tel: +31 (0)85 00 743 00  
[info@tapflo.nl](mailto:info@tapflo.nl)

### Poland

Tapflo Sp. z o.o.  
Tel: +48 58 530 42 12  
[info@tapflo.pl](mailto:info@tapflo.pl)

### Romania

S.C. Tapflo Rom. S.r.l.  
Tel: +40 21 3451255  
[sales@tapflo.ro](mailto:sales@tapflo.ro)

### Russia

Tapflo Company  
Tel: +7 495 232 18 28  
[sales@tapflo.com.ru](mailto:sales@tapflo.com.ru)

### Serbia

Tapflo d.o.o.  
Tel: +381 21 44 58 08  
[sales@tapflo.rs](mailto:sales@tapflo.rs)

### Slovakia

Tapflo s.r.o.  
Tel: +421 911 137 883  
[tapflo@tapflo.sk](mailto:tapflo@tapflo.sk)

### Slovenia

Tapflo GmbH  
Tel: +386 68 613 474  
[sales@tapflo.hr](mailto:sales@tapflo.hr)

### Spain

Tapflo Iberica  
Tel: +34 91 8093182  
[avives@tapfloiberica.es](mailto:avives@tapfloiberica.es)

### South Africa

Tapflo (Pty) Ltd  
Tel: +27 31 701 5255  
[sales@tapflo.co.za](mailto:sales@tapflo.co.za)

### Turkey

Tapflo Makina Ltd  
Tel: +90 216 467 33 11  
[sales@tapflo.com.tr](mailto:sales@tapflo.com.tr)

### Ukraine

TOB Tapflo  
Tel: +380 44 222 68 44  
[sales@tapflo.ua](mailto:sales@tapflo.ua)

### Uzbekistan

Tapflo Uzbekistan  
Tel: +998 712370940  
[sales@tapflo.uz](mailto:sales@tapflo.uz)

### United Kingdom

Tapflo (UK) Ltd  
Tel: +44 2380 252325  
[sales@tapflo pumps.co.uk](mailto:sales@tapflo pumps.co.uk)



If your country is not listed  
please visit  
[www.tapflo.com/en/contact](http://www.tapflo.com/en/contact)